

PRICE \$2.00

RCA ELECTRON-TUBE MICROMHOMETER

Type WT-100A

(Serial Nos. 1001 and Over)

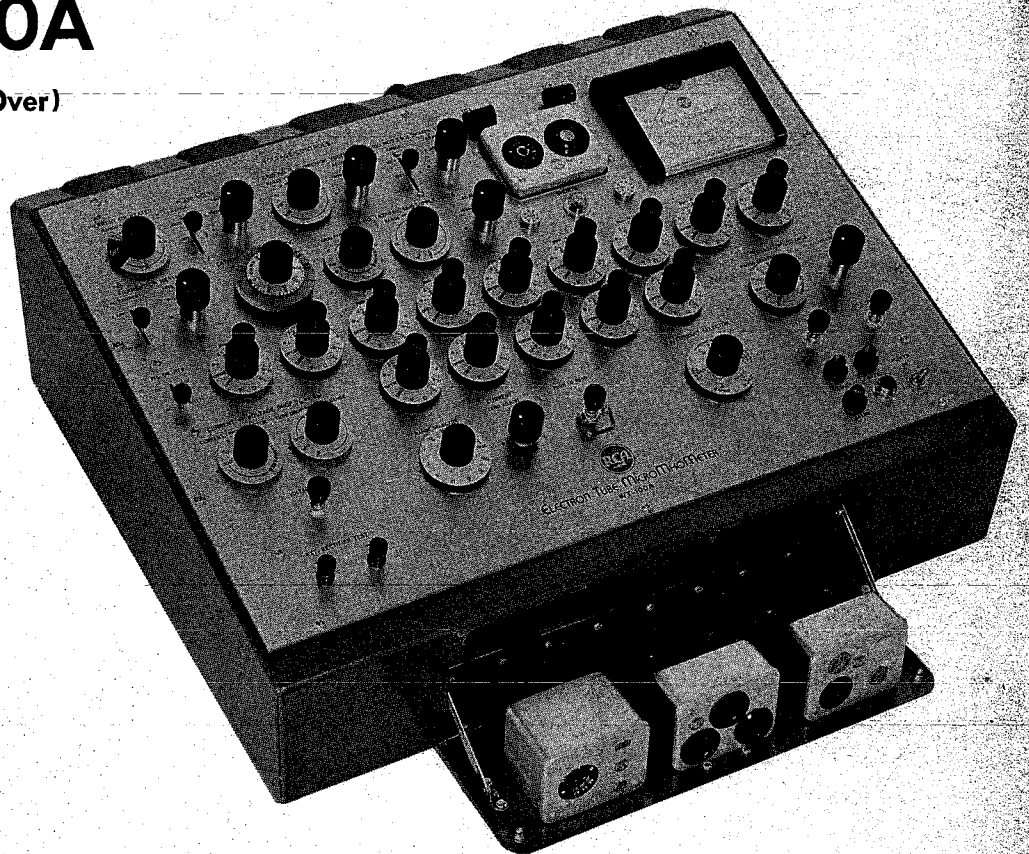

● Operation

● Specifications

● Typical Test-Setup Procedures



RADIO CORPORATION of AMERICA

ELECTRON TUBE DIVISION
ELECTRONIC INSTRUMENTS

HARRISON, N. J.
CAMDEN, N. J.

Safety Precautions

Operation of this instrument is simple and straightforward. However, normal precautions should be observed when operating or repairing any electronic equipment.

An important point to remember is that there is always danger inherent in testing electrical equipment which operates at hazardous voltages. Therefore, the operator should thoroughly familiarize himself with the equipment under test before working on it, bearing in mind that high voltages may appear at unexpected points in defective equipment. Additional precautions which experience in the industry has shown to be important are listed below.

1. It is good practice to remove power before connecting test leads to high-voltage points. If this is impractical, be *especially careful* to avoid accidental contact with equipment racks and other objects which can provide a ground. Working with one hand in your pocket and standing on a properly insulated floor

lessens the danger of shock.

2. Filter capacitors may store a charge large enough to be hazardous. Therefore, discharge filter capacitors before attaching test leads.

3. Remember that leads with broken insulation provide the additional hazard of high voltages appearing at exposed points along the leads. Check test leads for frayed or broken insulation before working with them.

4. To lessen the danger of accidental shock, disconnect test leads immediately after test is completed.

5. Remember that the risk of severe shock is only one of the possible hazards. Even a minor shock can place the operator in hazard of more serious risks such as a bad fall or contact with a source of higher voltage.

6. The experienced operator continuously guards against injury and does not work on hazardous circuits unless another person is available to assist in case of accident.

ITEMS

Supplied with the WT-100A

MULTIPLE-SOCKET PLUG-IN UNIT Type WG-229A Miniature 7-Contact, Noval 9-Contact, and Octal 8-Contact	MULTIPLE-SOCKET PLUG-IN UNIT Type WG-231A Small 4-Contact, Small 5-Contact, and Small 6-Contact
MULTIPLE-SOCKET PLUG-IN UNIT Type WG-230A Lock-in 8-Contact, and Combination including Small 7-Contact, Medium 7-Contact, as well as Large Center Contact for testing miniature lamps having screw- or bayonet-type bases	MULTIPLE-SOCKET PLUG-IN UNIT Type WG-232A Subminiature 8-Contact (Circular), Subminiature 7-Contact (In Line), and Acorn 7-Contact (For 5- and 7-pin types)
1 Registration Card	1 Instruction Booklet
1 "Hold Down" Latch for Current Push-To-Read-Button	
1 RCA-0A2	1 RCA-6CL6
1 RCA-5U4-GB	2 RCA-6U8 or 6U8-A
1 RCA-6AU6 or 6AU6-A	1 RCA-6X4
1 RCA-6DQ5	1 RCA-12AU7 or 12AU7-A

ITEMS

Available on separate order

INDUSTRIAL SOCKET PLUG-IN UNIT Type WG-233A Miniature 7-Contact
INDUSTRIAL SOCKET PLUG-IN UNIT Type WG-234A Octal 8-Contact
INDUSTRIAL SOCKET PLUG-IN UNIT Type WG-235A Noval 9-Contact
KIT OF PLUG-IN SOCKET PARTS Type WG-236A
NUVISTOR SOCKET PLUG-IN UNIT Type WG-340A

Information furnished by RCA is believed to be accurate and reliable. However, no responsibility is assumed by RCA for its use; nor for any infringements of patents or other rights of third parties which may result from its use. No license is granted by implication or otherwise under any patent or patent rights of RCA.

Electron-Tube MicroMhoMeter

Type WT-100A

Contents

	<i>Page</i>
Safety Precautions	2
Items Supplied with WT-100A.....	2
Items Available on Separate Order.....	2
General Description	4
Specifications	6
Functions of Controls and Terminals.....	7
Operation	10
General	10
To Measure Transconductance	10
To Measure Electrode Current.....	10
To Measure Cutoff Voltage.....	11
To Measure Voltage Drop of Rectifiers, Thyratrons, and Glow-Discharge Tubes.....	11
To Measure Forward and Reverse Current of Dry-Disc Rectifiers and Crystal Diodes.....	11
To Measure AC Heater Current.....	11
Adaptors for Pencil Tubes and Nuvistor Tubes.....	11
Precise Setting of Cathode Resistor.....	12
Typical Tube Test Setup Procedures.....	13
General	13
6AG7 Power Pentode.....	13
5U4-GB Rectifier	14
12SA7 Pentagrid Converter.....	16
2D21 Thyatron	17
OC2 Voltage Regulator.....	19
Application	19
Measurement of Screen-to-Plate Transconductance	19
Plate-Resistance (Rp) Measurements	20
Interelectrode Leakage	20
Heater-Cathode Leakage	21
Contact Potential	21
Reverse Grid Current	21
Measurement of Retarding Potential	21
Measurement of Reverse Grid Current.....	22
Circuit Description	22
Regulated Power Supply.....	22
Current Amplifier.....	22
gm Preamplifier	23
Transconductance Test Circuit.....	23
Ib vs Eb	24
Maintenance	24
General	24
Tube Replacement	24
Calibration of the Current Amplifier	25
Shorts-Test Circuit Check	25
Transconductance (gm) Circuit Check	25
Oscillator Circuit Check	27
AC-Heater Current Calibration.....	27
Replacement Parts List.....	28
Warranty.....	31
Schematic Diagram	31

General Description

The RCA WT-100A, Electron-Tube MicroMhoMeter, is a laboratory-type instrument designed to measure tube characteristics under operating-voltage and current conditions, with an accuracy approaching that of tube-manufacturers' equipment. The Electron-Tube MicroMhoMeter can accommodate the following types of electron tubes and semiconductor devices.

Entertainment Receiving Types

Receiving-Type Tubes for Industry
and Communications

Small Power and Gas Types

Cold-Cathode (Glow-Discharge) Types

Small Dry-Disc Rectifiers

Crystal Diodes

The instrument can be used to measure true transconductance, both control-grid-to-plate and suppressor-grid-to-plate values; electrode currents — plate, screen grid, suppressor grid, and control grid; ac heater current; and voltage drop of vacuum and gas tubes, dry-disc rectifiers and crystal diodes.

The specially designed transconductance-measuring circuit can be used to measure transconductance up to 100,000 micromhos. The instrument utilizes a unique calibrating circuit which permits direct measurement of actual transconductance without the need for external null indicators. This circuit also insures long-term accuracy and repeatability of test results by compensating for possible changes in component values due to the effects of aging and heat.

Test voltages are set to the desired values by means of individual controls for the filament or heater voltage, plate voltage, screen-grid voltage, suppressor-grid voltage, and the control-grid supply voltage. Cathode and control-grid resistors can be adjusted to desired values. The range of control voltages provides a means of measuring tube characteristics so that a direct comparison with tube manufacturers published data is possible.

Individual numbered switches for each tube base-pin permit the connection of any tube-base pin to the desired test circuit. The tube under test may therefore, be set up exactly as specified by the tube manufacturer, or

set up for conditions encountered in circuit applications. The switching arrangement is designed to accommodate up to 14 tube-base pins. Two top-cap connectors are also available. In addition, the instrument provides a shorts test which will indicate internal tube shorts or shorts to ground for each pin. Leakage resistance as high as two megohms will also be indicated by the shorts test.

The WT-100A provides two positive dc voltages and two negative dc voltages from an electronically regulated, heavy-duty power supply. The positive-voltage power supply can provide up to 300 milliamperes of plate current and up to 30 milliamperes of screen current. Plate and screen voltages are variable from 0 to 300 volts and regulation is within 3%. Negative voltages for the suppressor grid and the control grid are variable from 0 to 100 volts. The power supply has an effective impedance of less than 0.1 ohm at the test frequency. As a result, there is negligible error due to power supply impedance regardless of the plate resistance of the tube under test.

The ac filament or heater voltage is variable from 0 to 117 volts; and has an approximate power handling capability of 30 watts. The WT-100A also provides dc filament voltages from 0 to 3 volts up to 250 milliamperes.

A high-frequency oscillator operating at 45 Kc and a transconductance amplifier are used with the direct-reading transconductance measuring circuit. The amplifier, which is essentially flat from 15 Kc to 150 Kc, has an attenuation at a frequency of 60 cps of 54 db. As a result, the effects of residue power-supply ripple are eliminated. To insure accuracy in measuring high-transconductance tubes, the signal level is approximately 5 millivolts when the 100,000-micromho range is used. Transconductance of tubes having either high or low plate resistance may be accurately measured. High-perveance tubes may also be checked, even at zero bias, without error due to self-oscillation.

Electrode currents up to 300 milliamperes may be measured in 11 convenient ranges including low-current ranges for the measurement of small currents, such

as reverse grid-current. On the lowest range, a current of 3 microamperes will cause full-scale deflection of the meter. A current amplifier is utilized for all current measurements.

The Electron-Tube MicroMhoMeter provides a means for measuring voltage drop at plate currents up to 300 milliamperes. The regulation of gas-type voltage-regulator tubes, and the firing point of small thyratrons may also be determined. Test voltages for checking the forward and reverse current of dry-disc rectifiers and crystal-diode rectifiers are available from binding posts on the panel. When the WT-100A is used to check voltage drop, the device under test is protected by a current-limiting circuit, having four ranges of 3, 10, 100, and 300 milliamperes.

All measurements may be made on a single easy-to-read meter. The unique metering circuit provides linear deflection on all ranges and functions, the meter is electronically protected against burnout on all transconductance and current ranges. Other functions are protected by interlocking circuits. Meter multipliers and

shunts are automatically switched when a change is made from one type of measurement to another.

The four multiple-socket plug-in units supplied with the instrument will accommodate most tube types whose ratings are within the limits of the WT-100A. These multiple-socket plug-in units can be quickly and easily interchanged and can accommodate up to 14 base-pin connections. Should the need arise, new sockets may be added without difficulty. Industrial-type, heavy-duty sockets for production line testing are available on separate order.

The WT-100A, Electron-Tube MicroMhoMeter has a sufficient number of individual controls so that it may be set up according to tube manufacturers' published data. The instrument can also be set up to provide the operating voltages of a circuit of specific design to determine the performance of a tube under the desired voltage conditions. The wide range of controls and the flexibility of this instrument make it a valuable tool for production line and laboratory testing and circuit design engineering.

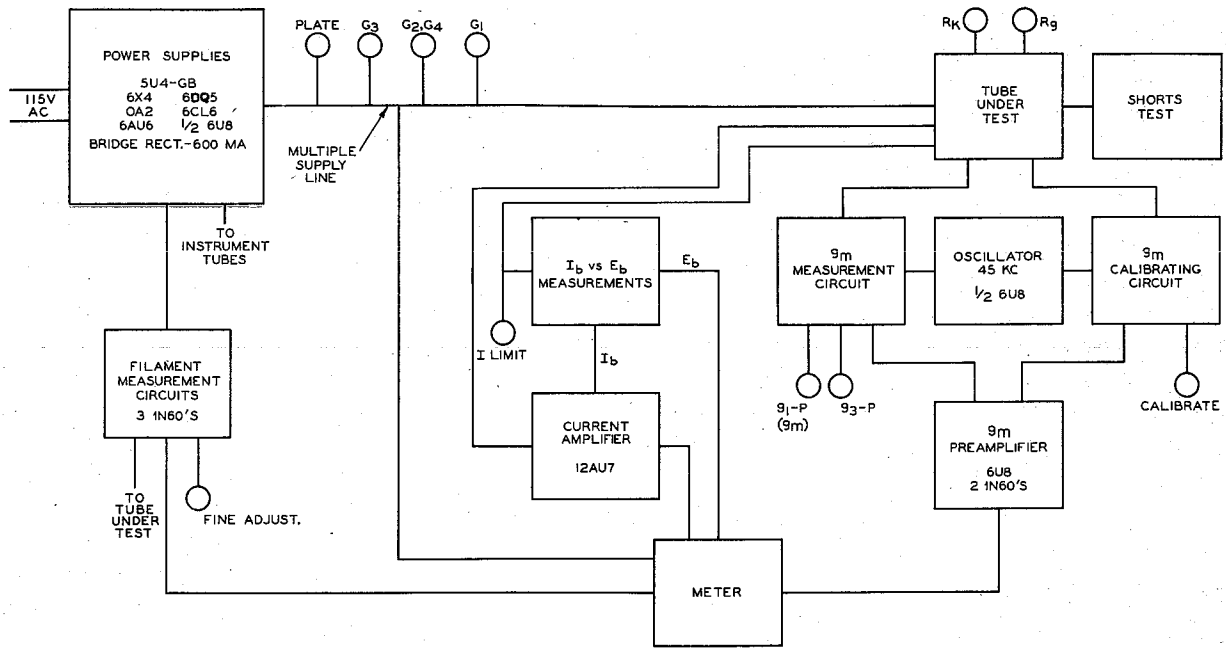

Figure 1. Block diagram of the WT-100A

Functions of Controls and Terminals

Voltage Controls

FILAMENT OR HEATER:

RANGE SELECTOR—Used in conjunction with the **FILAMENT** or **HEATER FINE ADJUST**. The range of filament or heater voltage required is selected by means of this switch. The markings on the skirt indicate the voltage range, and the meter scale. Meter multipliers are automatically changed when the **RANGE SELECTOR** is switched to a given range.

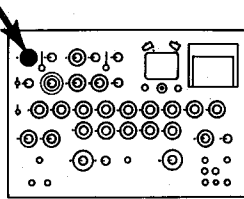

FINE ADJUST Push To Read—Used in conjunction with the **FILAMENT** or **HEATER RANGE SELECTOR**. Permits precise adjustments of the filament or heater voltage, and when depressed connects the meter to the filament circuit. Depress the knob and rotate it to adjust and meter the voltage at the same time.

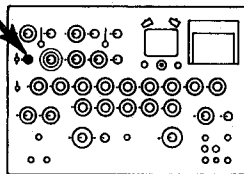

0-3V DC, 0-117V AC—Provides a choice of either dc or ac filament or heater voltage. In the “DC” position, dc filament voltage up to 3 volts is available. The **FILAMENT** or **HEATER RANGE SELECTOR** must be set to the “0-3” position. The **FILAMENT** or **HEATER FINE ADJUST** is used to set the desired voltage. In the “AC” position, ac heater voltage up to 117 volts is available.

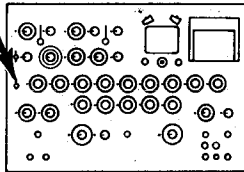

AC CURRENT 1 AMP—**10 AMP**—Used in conjunction with the **FILAMENT** or **HEATER FINE ADJUST** to measure ac heater current. With this switch in either the “1 AMP” or “10 AMP” position, the meter is placed in series with the heater under test when the **FILAMENT** or **HEATER FINE ADJUST** knob is depressed. Meter shunts are switched automatically when the 1 AMP — 10 AMP switch is used in either position.

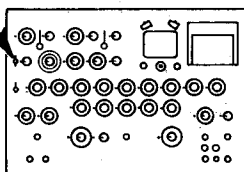
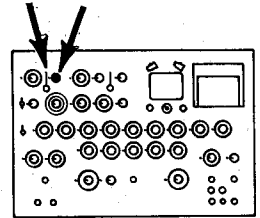

PLATE VOLTS:

RANGE — 3-position lever-action switch, selects desired voltage range.

ADJUST Push To Read—Permits continuous adjustment of the plate voltage over the range indicated by the setting of the lever-action switch. Clockwise rotation increases the voltage. Depressing the knob connects the meter into the plate circuit. Depress the knob and rotate it to adjust and meter the voltage at the same time.



GRID-NO. 3 (SUPPRESSOR) VOLTS:

RANGE SELECTOR—The range of Grid-No. 3 (G_3) voltage is selected by means of this switch. Meter multipliers are switched automatically as the voltage range is changed. The values on the skirt of the switch indicate the voltage range and the meter scale.

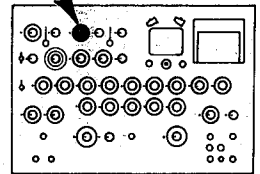

ADJUST Push To Read—Used in conjunction with the **RANGE SELECTOR** to set the G_3 voltage to the desired value. Depressing the knob connects the meter to the G_3 supply. Depress the knob and rotate it to adjust and meter the voltage at the same time.

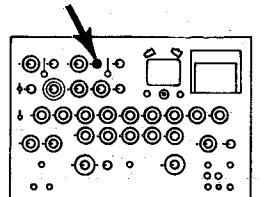

GRIDS-NO. 2 & 4 (SCREEN) VOLTS:

RANGE — 3-position lever-action switch, selects desired voltage range.

ADJUST Push To Read—Permits continuous adjustment of the Grid-No. 2 (G_2) and Grid-No. 4 voltage over the range indicated by the setting of the lever-action switch. Clockwise rotation increases the voltage. Depressing the knob connects the meter into the G_2 , G_4 circuit. Depress the knob and rotate it to adjust and meter the voltage at the same time.

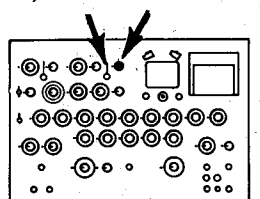

GRID-NO. 1 (CONTROL GRID) SUPPLY VOLTS:

RANGE SELECTOR — The range of negative control-grid voltage required is selected by means of this switch. The values on the skirt of the switch indicate the voltage range and the meter scale. Meter multipliers are switched automatically when the voltage range is changed.

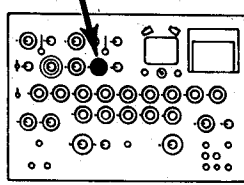

ADJUST Push To Read — Used in conjunction with the Grid-No. 1 RANGE SELECTOR to set the G_1 voltage to the desired value. Depress the knob and rotate it to adjust the voltage at the same time.

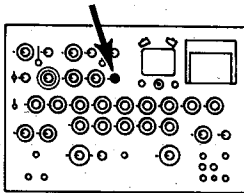

GRID RESISTOR — Provides a choice of grid resistance and is the Grid No. 1 return for the tube under test. The "gm" position marked on the skirt of the control is used when fixed or cathode bias is used. When a grid resistor is used to provide bias, or when gas current is to be measured, this control is set to the value specified in the tube data.

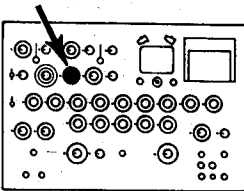

CATHODE RESISTOR: Provides a choice of cathode resistor value and is the cathode return for the tube under test. Total cathode resistance is the sum of the resistance values indicated by the inner and outer dials. These controls should be set to zero when fixed bias is used. When cathode bias is used, the control should be set to the value specified in the tube data.

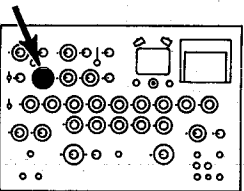

SHORTS TEST:

Depressing the push button on top of each pin switch checks the corresponding tube element for shorts to all other elements and to ground. Interelectrode shorts or interelectrode leakage resistance up to 2 megohms will cause the neon indicator to glow. The gm/CURRENT SELECTOR must be set to the "Read gm—SHORTS" position.

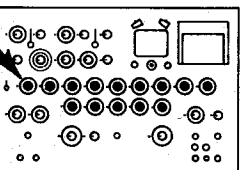

PIN SWITCHES:

Each switch can be set to connect the corresponding pin of the tube under test to any desired test circuit as follows:

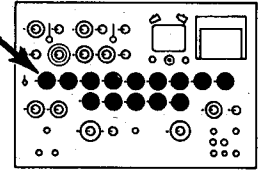

- H(+)—One side of heater or filament (+)
- H—K(—) Other side of heater or filament, (—) and/or Cathode
- P—Plate
- G_3 —Suppressor Grid Note; for tubes which have a separate pin connection for G_3 , connect the appropriate pin switch as specified in the tube data. i.e.: H-K, (—) or Gnd.
- G_2 —Screen Grid
- G_1 —Control Grid
- I_b vs. E_b —Plate or positive (+) terminal of device under test for voltage drop measurement
- B+—Positive plate-voltage supply output terminal
- Open—No connection
- Gnd—Instrument chassis ground
- Δ or \square —Blank positions

gm/CURRENT SELECTOR:

Functions of switch position are as follows:

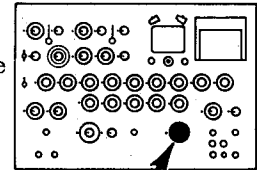

- "Read gm—Shorts"—Permits the calibration of the transconductance circuit; permits the measurement of transconductance; and permits the shorts test.
- "Zero Adj I_b — I_{c3} — I_{c2} "—Permits the calibration of the current amplifier for plate, suppressor-grid, and screen-grid current measurements.
- "Read I_b "—Permits measurement of plate current.
- "Read I_{c3} "—Permits the measurement of suppressor-grid current.
- "Read I_{c2} "—Permits the measurement of screen-grid current.
- "Zero Adj I_{c1} "—Permits calibration of the current amplifier for control-grid current measurements.
- "Read I_{c1} "—Permits the measurement of control-grid current.

This control, when used for all measurements except gm and the shorts test, is used in conjunction with the Current-Range Selector, Current Zero Adjust and the Current Push-to-Read controls.

CURRENT:

RANGE SELECTOR — This switch should be set to a range which includes the maximum anticipated current to be read. Meter shunts are switched automatically as the range is changed.

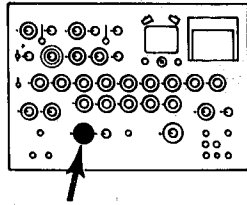

ZERO ADJUST — The current amplifier circuit is balanced by means of this control. Under no-current-flow conditions the meter reads zero for a properly balanced current amplifier.

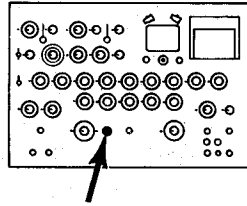

PUSH TO READ—Depressing this button applies voltages to the tube under test and places the meter across the current amplifier. The meter indicates current flow when the gm/CURRENT SELECTOR is in any of the "Read" positions and unbalance in the current amplifier when the gm/CURRENT SELECTOR is in any of the "Zero Adj" positions. An accessory "hold-down" latch is provided to keep the tube operating in cases where the effect of increased heat, gas, or other phenomena is to be observed. This hold-down latch may be installed by slipping the ends into the mounting holes in the base of the control.

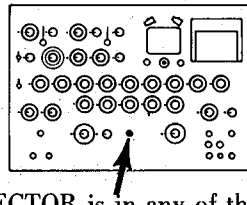

CAUTION: Remove hold down latch after desired readings have been taken. Do not change pin connections or change the tube under test unless the CURRENT Push-to-Read button is in its off position, because all circuits are energized by this button.

Current vs Voltage Drop (I_b vs E_b)

CURRENT LIMIT SELECTOR:

The setting of this switch limits the maximum current through any device connected to the I_b vs. E_b position of the pin switches, or connected to the external Rectifier Test Terminals, to the value indicated on the skirt of the selector.

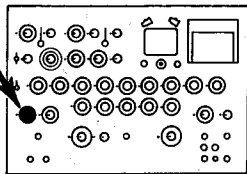

TUBE DROP VOLTAGE RANGE:

The setting of this switch determines the meter range for measuring the voltage drop across the device under test. The switch is spring-loaded to return to the 300 volt position.

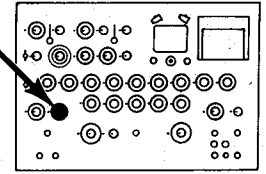

VOLTAGE DROP:

This button applies test voltages to the device under test and connects the meter across the device, so that voltage drop at a desired current value may be determined. The voltage drop function is used in conjunction with the I_b vs. E_b position on the pin switches.

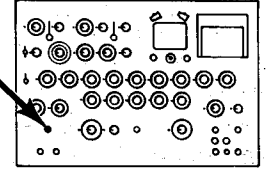

TRANSCONDUCTANCE:

RANGE SELECTOR—This switch should be set to a range which includes the maximum transconductance to be read. Meter multipliers are switched automatically when the range is changed.

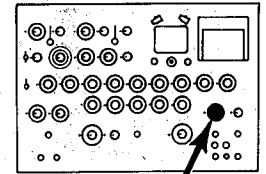

CALIBRATE Push to Read—The gm amplifier is calibrated under load conditions by means of this control. Depressing the knob and rotating it connects the meter to the transconductance amplifier circuit and energizes the instrument to permit adjustment of the calibrating circuit.

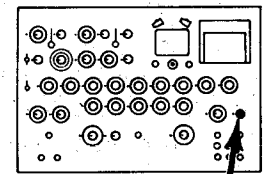

G_1 -P (gm)—Depressing the button applies test voltages to the tube under test and connects the meter to the control - grid - transconductance-measuring circuit.

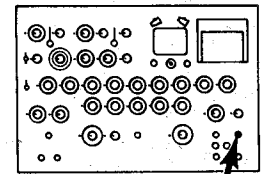

G_3 -P—Depressing this button applies test voltages to the tube under test and connects the meter to the suppressor - grid - transconductance-measuring circuit.

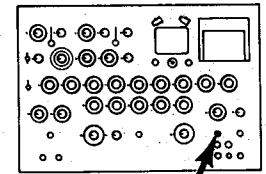

POWER:

Applies power-line voltage to the tester when switched to the "on" position.

Operation

General

Operation and setup of the WT-100A is simple and straightforward. In most cases, tube manufacturer's data may be used directly. The "Typical Tube Test Setup Procedures" section contains step-by-step instructions for testing four representative tube types. In general, the procedure for measuring tube characteristics is as follows:

1. Connect the power cord at the rear of the instrument to a 60 cps, 105-125 volt source. Turn instrument "on".
2. Insert appropriate Multiple-Socket Plug-in Unit in the receptacle next to the meter.
3. Turn all voltage controls fully counterclockwise. Set the CATHODE RESISTOR control to "0", and the GRID RESISTOR control to "gm".
4. Adjust the filament voltage to the required value.
5. Set the pin switches to correspond to the pin connections on the tube base diagram in the tube manufacturer's data. (See "Pin Switches" under Functions of Controls and Terminals.) Each unit of a multi-unit tube is checked separately.
6. Insert the tube in the Multiple-Socket Plug-in Unit.
7. Readjust filament or heater voltage if necessary.
8. Set the gm/CURRENT SELECTOR switch to the "Read gm—SHORTS" position.
9. Check for shorts by individually depressing the push buttons on top of each pin switch. The SHORTS indicator will glow if an internal short, a short to ground, or leakage resistance up to two megohms is present. Filament continuity and internal connections will also be indicated by the shorts indicator. Note: It is possible that several tube elements are normally connected internally. Always check the tube base diagram for elements that are normally connected together.

To determine whether the short indication is due to

a tube fault and is not an indication of an internal connection, proceed as follows:

- a. Check the tube base diagram to determine the internal connections between base pins. Simultaneously depress all push buttons that correspond to the connected base pins. The neon indicator will extinguish if there are no shorts.
- b. To identify a shorted element, depress and hold the push button or buttons which gives a short indication, and depress each of the remaining push buttons individually. When the indicator is extinguished, a short exists between the tube element whose push button caused the short indication, and the one that extinguished it.

To Measure Transconductance

10. Adjust the voltages to the specified values, or to the values required for a specific application.
11. Set the transconductance RANGE SWITCH to a range which includes the maximum anticipated reading.
12. Set the gm/CURRENT SELECTOR switch to the "Read gm" position.
13. Calibrate the transconductance measuring circuit by depressing the CALIBRATE control and rotating it for full scale deflection of the meter pointer.
14. Press the g_1 -P (gm) push button to read control-grid-to-plate transconductance (gm).
15. Press the g_3 -P push button to read suppressor-grid-to-plate transconductance.

To Measure Electrode Current

1. Follow steps 1 through 9 given above.
2. Set the current RANGE SELECTOR switch to a range which includes the maximum anticipated current.
3. Set the gm/CURRENT SELECTOR switch to the "Zero Adj" position of the electrode current to be measured.

4. Zero adjust the current amplifier by holding down the current push button and rotating the ZERO ADJUST control for "zero" reading on the meter.
5. Set the gm/CURRENT SELECTOR switch to the "Read" position of the electrode current to be measured.
6. Press the current "Push to read" push button.

To Measure Cutoff Voltage

1. Set up the instrument to read plate current or transconductance as outlined on pages #10 and #11, using the tube manufacturer's data.
2. Rotate the "GRID-NO. 1 (Control Grid) SUPPLY VOLTS/ADJUST" control clockwise, thus increasing the bias voltage until the plate current or transconductance is reduced to the cutoff value specified in the tube manufacturer's data (reset "RANGE SELECTOR" if necessary).
3. Release the "G1-P (gm)" or "CURRENT/PUSH TO READ" button (depending on the test being performed).
4. Depress the "GRID-NO. 1 (Control Grid) SUPPLY VOLTS/ADJUST" control, and read the Grid-No. 1 voltage on the meter.

Note: In some tubes, such as Gated Amplifiers, both Grid-No. 1 and Grid-No. 3 may be used as control electrodes. For such tubes set the Grid-No. 1 voltage to the value specified in the tube data and increase the Grid-No. 3 (Suppressor-Grid) Voltage in the same manner as described for Grid-No. 1.

To Measure Voltage Drop of Rectifiers, Thyratrons, and Glow-Discharge Tubes

Follow steps 1-4 given in the general procedure.

CAUTION: All voltage controls should be turned fully counterclockwise.

5. Set the pin switches to correspond to the tube-base diagram. Set the pin switch which corresponds to the plate or anode to the " I_b vs. E_b " position.
6. Insert the tube in the Multiple Socket Plug-in Unit.
7. Readjust filament or heater voltage if necessary.
8. Check for shorts. The gm/CURRENT SELECTOR switch must be on the "Read gm—SHORTS" position.
9. Set the CURRENT LIMIT SELECTOR switch to the lowest range which includes the maximum anticipated current.
10. Set up instrument to read plate current (I_b).

11. Hold the CURRENT "Push to Read" push button down, and slowly increase the plate voltage until the desired current is indicated. If more control is desired while the plate current is being adjusted, set the CATHODE RESISTOR fully clockwise.

12. Release the "Push to Read" push button and depress the VOLTAGE DROP push button. The meter will indicate the voltage drop of the device.

To Measure Forward and Reverse Current of Dry-Disc Rectifiers and Crystal Diodes

1. Turn instrument "on" and set all voltage controls fully counterclockwise.
2. Connect the device to be checked across the "+" and "-" Binding Posts, with the anode connected to "+" and the cathode to "-".
3. Set the CURRENT LIMIT SELECTOR switch to the lowest range which includes the maximum anticipated current.
4. Set the instrument to measure plate current (I_b).
5. Measure plate current while increasing the plate voltage until the desired plate current is indicated. If more control is desired while the plate current is being adjusted, set the CATHODE RESISTOR fully clockwise.
6. Depress the VOLTAGE DROP push button and read the voltage drop.
7. Reduce plate voltage to its lowest value.
8. Reverse the diode so that the anode is connected to the "-" Binding Post and the cathode is connected to the "+" Binding Post.
9. Repeat steps 3 through 6.

To Measure AC Heater Current

1. Follow steps 1 through 7 given in the General procedure.
8. Set the AC CURRENT 1 AMP-10 AMP switch to either the "1 AMP" or the "10 AMP" position. It will be necessary to hold this switch in position because the switch is spring loaded to return to the center or off position.
9. Depress the FILAMENT or HEATER FINE ADJUST and read the current on the appropriate meter scale.

Adaptors for Pencil Tubes and Nuvistor Tubes

The WG-236A is an unwired plug-in unit with a blank panel. This unit may be used for setting up

socket connections for tubes which do not have conventional bases. For example, the WG-236A plug-in unit may be adapted to accommodate pencil tubes. Two fuse clips, insulated from the unit, may be used to support the tube and serve as terminal connectors for the cathode and anode. A flexible lead and a spring clip should be used for the grid connector. All pencil tube heaters fit a standard subminiature socket such as the Cinch No. 54A16325 or equivalent.

It is recommended that the plug-in unit socket be wired as follows.

Pin 1: Plate connector	Pin 4: Heater
Pin 2: Heater	Pin 5: Cathode connector
Pin 3: Grid connector	

An alternate adaptor which utilizes the octal socket of the plug-in unit supplied with the WT-100A may be made, by wiring an octal plug as indicated above. Fuse clips may be mounted on a separate board to support the tube. Since excessive pressure will damage the tube, connections to the electrodes should be made by means of flexible spring contacts only.

The RCA WG-340A Nuvistor Socket Plug-in Unit adaptor is available for use with the WG-229A Multiple-Socket Plug-in Unit that is supplied with the instrument. Connections to the Nuvistor electrodes are identified on the WG-340A adaptor and permit operation of the WT-100A controls in the same manner as for other tube types.

Precise Setting of Cathode Resistor

If desired, an external meter may be used to set precise values of cathode resistance.

To measure the exact value of the cathode resistor, turn the instrument off and connect a Wheatstone Bridge across TC1 and TC2.

1. Set Pin Switch 13 (TC1) to "GND", and set Pin Switch 14 (TC2) to "-H-K".

2. Set the Wheatstone Bridge to the value of cathode resistance required.

3. Adjust the CATHODE RESISTOR control until the bridge is balanced. Disconnect the bridge.

Typical Tube Test Setup Procedures

Procedures for testing four representative tube types — three entertainment receiving tubes and a gas thyatron are given below. It is suggested that the user familiarize himself with the operation of the various controls by going through these procedures several

unit which contains the appropriate tube socket into the receptacle next to the meter. Turn all electrode voltage controls to their maximum counterclockwise position. Set the CATHODE RESISTOR control (P) to "0", and the GRID RESISTOR control (Q) to "gm".

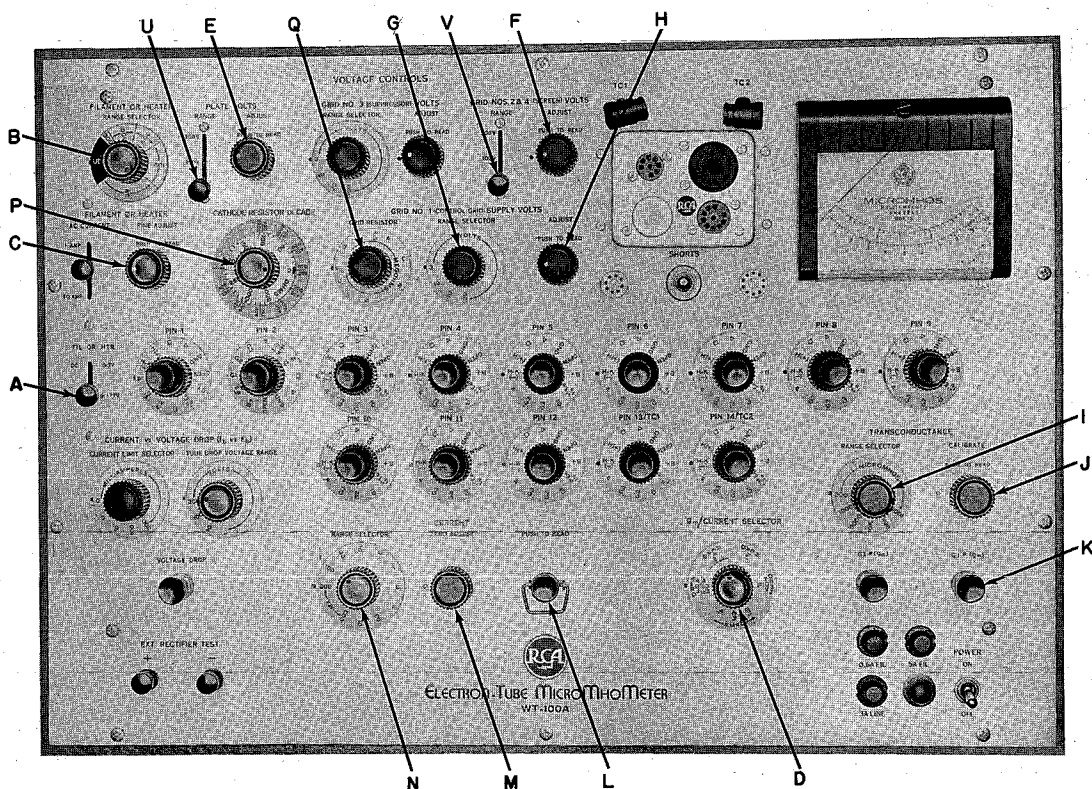

Figure 2. Controls used in testing a 6AG7 Power Pentode

times. All test data were taken from the RCA HB-3 Tube Handbook. Note that the published test results are average values based on an evaluation of a large number of tubes. Individual tubes may vary substantially from the published values.

General

Connect the power cord located at the rear of the instrument to a 60-cps, 105-125 volt source. Turn the instrument on, and insert the multiple-socket plug-in

6AG7 Power Pentode

The 6AG7 has been chosen as an example for the measurement of Transconductance, Plate Current and Grid-No. 2 Current. The measurements for this type are made under the following typical conditions: Heater Voltage (ac) 6.3 volts; Plate Voltage, 300 volts; Grid-No. 2 Voltage, 150 volts; Grid-No. 1 Voltage, -3 volts.

Under these conditions, the average values of the

test results are as follows: Transconductance, 11,000 μ mhos; Zero-Signal DC Plate Current, 30 ma; Zero-Signal DC Grid Current, 7 ma. Individual tubes may vary substantially from these values.

Socket Connections:

- | | |
|--------------------------|-------------------|
| Pin 1: Shell, Grid-No. 3 | Pin 5: Cathode |
| Pin 2: Heater | Pin 6: Grid-No. 2 |
| Pin 3: No Connection | Pin 7: Heater |
| Pin 4: Grid-No. 1 | Pin 8: Plate |

1. Set the pin switches to correspond to the socket connections.

- | | |
|----------------|----------------|
| Pin 1: Gnd | Pin 5: H-K (-) |
| Pin 2: H-K (-) | Pin 6: G_2 |
| Pin 3: Open | Pin 7: H+ |
| Pin 4: G_1 | Pin 8: P |

2. Set the 0-3V DC, 0-117V AC switch (A) to the 0-117V AC position.

3. Set the FILAMENT or HEATER RANGE SELECTOR (B) to the "10V" range. Depress the FINE ADJUST control (C) and adjust it for a reading of 6.3 volts on the meter. If the FINE ADJUST does not have sufficient control to set the precise voltage, change the setting of the Range switch within the 10 volt range. Clockwise rotation increases the voltage, counterclockwise rotation decreases it.

4. Insert the 6AG7 in the octal socket. Allow 15 seconds for warmup.

5. Readjust Heater Voltage, if necessary.

6. To check for shorts, first set the gm/CURRENT SELECTOR switch (D) to the "Read gm-SHORTS" position and then depress the push button on top of each pin switch. Pins number 2 and 7 should show an internal connection. Depressing pushbuttons, No. 2 and 7 simultaneously should extinguish the neon bulb.

See step 9 in the General Operation section.

7. If no shorts are indicated, set the PLATE VOLTS RANGE lever switch (U) to the "300V" position, then depress the PLATE VOLTS ADJUST (E) and adjust the plate voltage to 300 volts.

8. Set the GRID NOS. 2 & 4 (SCREEN) VOLTS RANGE lever switch (V) to the "300V" position, then depress the GRID NOS. 2 & 4 (SCREEN) VOLTS ADJUST (F) and adjust the G_2 voltage to 150 volts.

9. Set the GRID-No. 1 (Control Grid) VOLTS RANGE SELECTOR (G) to the 3-volt range. Depress the ADJUST control (H) and set the voltage to 3 volts.

10. Set the TRANSCONDUCTANCE RANGE SELECTOR switch (I) to the 30K range.

11. Calibrate the gm measuring circuit by depressing the CALIBRATE control (J). Adjust it for full-scale deflection of the meter pointer.

12. Press the G_1 -P (gm) pushbutton (K) and read the transconductance.

13. Set the gm/CURRENT SELECTOR switch to the "ZERO ADJ I_b, I_{c3}, I_{c2} " position. Balance the current amplifier by depressing the CURRENT push-to-read pushbutton (L) and simultaneously adjust the ZERO ADJUST control (M) so that the meter reads "0".

14. Set the gm/CURRENT SELECTOR switch to the "Read I_b " position.

15. Set the CURRENT RANGE SELECTOR switch (N) to 100 ma.

16. Depress the CURRENT Push-to-Read pushbutton and read the plate current.

17. Set the gm/CURRENT SELECTOR switch to the "Read I_{c2} " position.

18. Set the CURRENT RANGE SELECTOR switch to 10 ma.

19. Depress the CURRENT Push-to-Read pushbutton and read the screen current.

5U4-GB Rectifier

The 5U4-GB was chosen as an example for the measurement of Tube voltage drop, which is the voltage at a specified current between the anode and the cathode of the device under test. The measurements for this type are made under the following typical conditions: Heater Voltage (ac), 5 volts; Anode Voltage adjusted to give 275 ma/plate.

Under these conditions the average value of the voltage drop is 50 volts. Individual tubes may vary substantially from this value.

Socket Connections:

- | | |
|----------------------------|----------------------------|
| Pin 1: No connection | Pin 6: Plate of Unit No. 1 |
| Pin 2: Filament | Pin 7: _____ |
| Pin 3: _____ | Pin 8: Filament |
| Pin 4: Plate of Unit No. 2 | Pin 5: _____ |

1. Set the pin switches to correspond to the socket connections. Check each section separately.

- | | |
|-----------------------|----------------|
| Pin 1: Open | Pin 5: Open |
| Pin 2: H+ | Pin 6: Open |
| Pin 3: Open | Pin 7: Open |
| Pin 4: I_b vs E_b | Pin 8: H-K (-) |

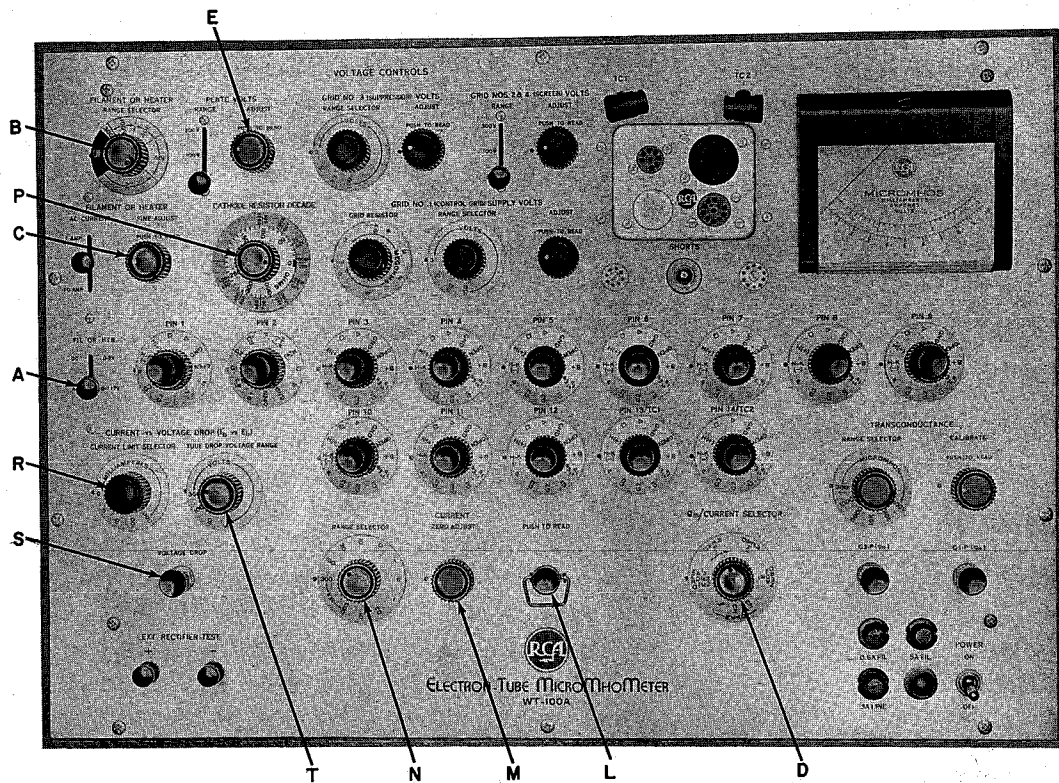

Figure 3. Controls used in testing a 5U4-GB Rectifier

2. Set the FILAMENT 0-3V DC, 0-117V AC (A) switch to the "0-117V AC" position.

3. Set the FILAMENT or HEATER RANGE SELECTOR (B) to the 10V range. Depress the FINE ADJUST control (C) and adjust it for a reading of 5 volts on the meter. If the FINE ADJUST does not have sufficient control to set the precise voltage, change the setting of the RANGE switch within the 10-volt range. Clockwise rotation increases the voltage, counterclockwise rotation decreases it.

4. Insert the 5U4-GB in the octal socket. Allow 15 seconds for warmup.

5. Readjust the filament voltage if necessary.

6. To check for shorts first set the gm/CURRENT SELECTOR switch (D) to the "Read gm-SHORTS" position and then depress the push button on top of each pin switch. Pin numbers 2 and 8 should show an internal connection. Depressing both pushbuttons No. 2 and 8 simultaneously should extinguish the neon bulb. See step 9 in the General Operation section.

7. If no shorts are indicated, set the gm/CURRENT SELECTOR switch (D) to the "Zero Adj. I_b , I_{c3} , I_{c2} " position. Balance the current amplifier by depressing the CURRENT Push-to-Read pushbutton (L) and simultaneously adjust the ZERO ADJUST control (M) so that the meter reads "0".

8. Set the gm/CURRENT SELECTOR switch to the "Read I_b " position.

9. Set the CURRENT RANGE SELECTOR switch (N) to the "300 ma" position.

10. Set the CURRENT LIMIT switch (R) to the "300 milliamperes" position.

11. Note: The plate voltage adjust should be set fully counterclockwise before any current readings are attempted.

Press the CURRENT Push-to-Read pushbutton and simultaneously increase the plate voltage by rotating the PLATE VOLTS ADJUST (E) clockwise, until a current flow of 275 ma is indicated on the meter. For greater control during this adjustment, set the CATHODE RESISTOR (P) fully clockwise.

12. Release the CURRENT Push-to-Read pushbutton and press the VOLTAGE DROP pushbutton (S). Read the voltage drop on the meter. If the meter pointer deflection is insufficient, set the TUBE DROP VOLTAGE RANGE switch (T) to a lower range. It will be necessary to hold this switch in position while a reading is taken because the switch is spring-loaded to return it to the 300-volt range.

13. Set the Pin 4 switch to "open" and set the Pin 6 switch to I_b vs E_b . Repeat steps 6 through 11.

12SA7 Pentagrid Converter

The 12SA7 has been chosen as an example for the measurement of transconductance of a converter under non-oscillating conditions. Transconductance is measured between Grid-No. 1, and Grids-No. 2 & 4 and Plate connected together. The measurement for this type is made under the following typical conditions: Heater Voltage, 12.6 volts; Grids-No. 2 & 4 and Plate Voltage, 100 volts; Grid-No. 1, Grid-No. 3, and Shell Voltage, 0 volts.

Under these conditions, the average value of the transconductance is 4500 μ mhos. Individual tubes may vary substantially from this value.

Socket Connections:

- Pin 1: { 12SA7—Shell, Grid-No. 5
12SA7GT—No connection
- Pin 2: Heater
- Pin 3: Plate
- Pin 4: Grids-No. 2 & 4
- Pin 5: Grid-No. 1
- Pin 6: { 12SA7—Cathode
12SA7GT—Cathode & Grid-No. 5
- Pin 7: Heater
- Pin 8: Grid-No. 3

1. Set the pin switches to correspond to the socket connections.

- | | |
|-----------------|----------------|
| Pin 1: Gnd Open | Pin 5: G_1 |
| Pin 2: H-K (-) | Pin 6: H-K (-) |
| Pin 3: P | Pin 7: H (+) |
| Pin 4: P | Pin 8: Gnd |

2. Set the 0-3V DC, 0-117V AC switch (A) to the 0-117V AC position.

3. Set the FILAMENT or HEATER RANGE SELECTOR (B) to the "30V" range. Depress the FINE ADJUST control (C) and adjust it for a reading of 12.6 volts on the meter. If the FINE ADJUST does not have sufficient control to set the precise voltage, change the setting of the RANGE SWITCH within the "30V" range. Clockwise rotation increases the voltage, counterclockwise rotation decreases it.

4. Insert the 12SA7 in the octal socket.

5. Readjust heater voltage, if necessary.

6. To check for shorts first set the gm/CURRENT SELECTOR switch (D) to the "Read gm-SHORTS" position and then depress the pushbutton on top of each pin switch. Pins number 2 and 7 should show an internal connection. Depressing pushbuttons corresponding to pins 2 and 7 simultaneously should

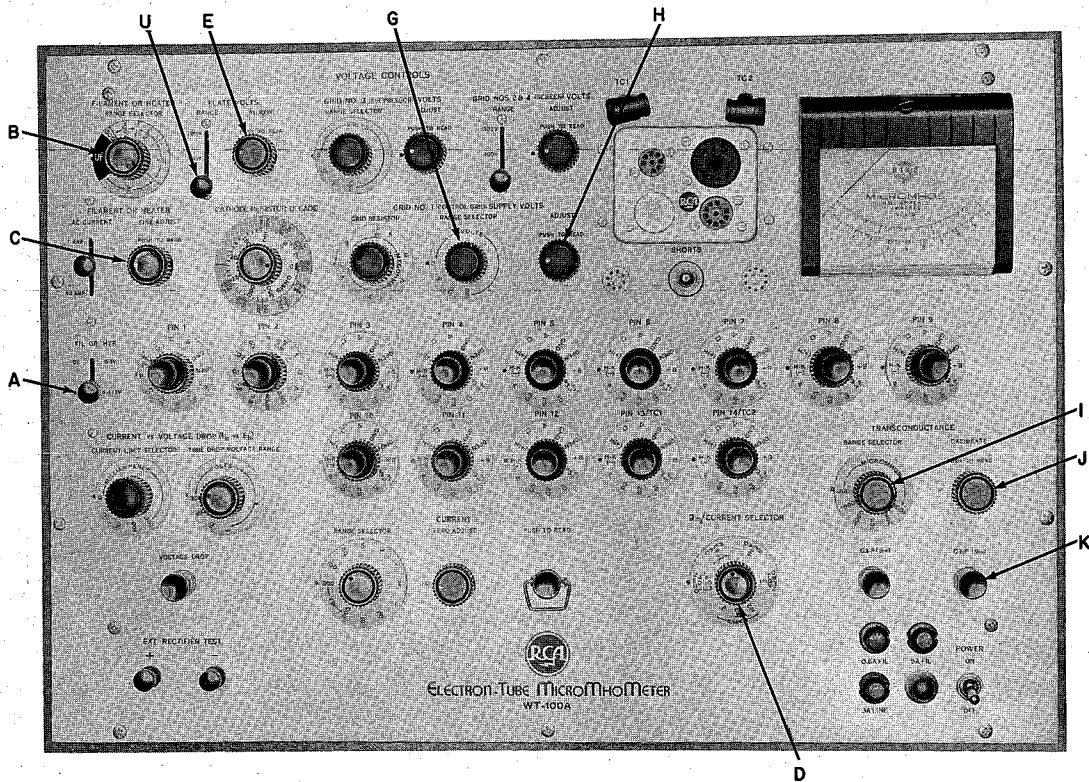

Figure 4. Controls used in testing a 12SA7 Pentagrid Converter

extinguish the neon bulb. See step 9 in the General Operation section.

7. If no shorts are indicated, set the PLATE VOLTS lever switch (U) to the "100V" position, then depress the PLATE VOLTS ADJUST (E) and adjust the plate voltage to 100 volts.

8. Check the G_1 voltage. Set the GRID-No. 1 (Control-Grid Supply) VOLTS RANGE SELECTOR (G) to the "3V" range. Depress the ADJUST control (H) and set it fully counterclockwise. NOTE: It is possible that a small value of voltage will be indicated under these conditions. This voltage may be due to contact potential. If a voltage is indicated, remove the 12SA7 from the socket and depress the Grid-No. 1 ADJUST control. If the meter remains at "0", no voltage is being applied to Grid-No. 1 from the power supply. Reinsert the tube.

9. Set the TRANSCONDUCTANCE RANGE SELECTOR (I) to the "10K" range.

10. Calibrate the gm measuring circuit by depressing the CALIBRATE control (J). Adjust it for full scale deflection of the meter pointer.

11. Press the G_1 -P (gm) pushbutton (K) and read the transconductance.

2D21 Thyatron

The 2D21 was chosen as an example for the measurement of the firing voltage of a thyatron and the measurement of the critical Grid-No. 1 voltage. The two test procedures are given below.

Method 1

This method is a zero-bias test with Grid-No. 1 and Grid-No. 2 tied to the cathode. The measurement of the value of the anode voltage required to cause this type to conduct is made under the following conditions: Heater Voltage (ac), 6.3 volts; Grid-No. 2, Grid-No. 1, and Cathode, 0 volts.

Under these conditions the average value of the DC Anode Voltage is 21 volts. Individual tubes may vary substantially from this value.

Socket Connections:

Pin 1: Grid-No. 1	Pin 5: Grid-No. 2
Pin 2: Cathode	Pin 6: Anode
Pin 3: Heater	Pin 7: Grid-No. 2
Pin 4: Heater	

1. Set the pin switches to correspond to the socket

connections with the cathode, Grid-No. 1 and Grid-No. 2 connected to the cathode, and the anode to the I_b vs E_b position.

Pin 1: H-K (-)	Pin 5: H-K (-)
Pin 2: H-K (-)	Pin 6: I_b vs E_b
Pin 3: H-K (-)	Pin 7: H-K (-)
Pin 4: H(+)	

2. Set the 0-3V DC, 0-117V AC switch (A) to the 0-117V AC position.

3. Set the FILAMENT or HEATER RANGE SELECTOR (B) to the "10V" range. Depress the FINE ADJUST control (C) and adjust it for a reading of 6.3 volts on the meter.

4. Insert the 2D21 in the seven-pin-miniature socket. Allow 15 seconds for warmup. Readjust heater voltage if necessary.

5. To check for shorts, first set the gm/CURRENT SELECTOR switch (D) to the "Read gm-SHORTS" position and then depress the push button on top of each pin switch. Pins number 3 and 4 and pins number 5 and 7 should show an internal connection. Depressing pushbuttons No. 3 and 4 simultaneously should extinguish the neon bulb. Similarly, depressing pushbuttons No. 5 and 7 simultaneously should extinguish the neon bulb. See step 9 in the general operation section.

6. Set the gm/CURRENT SELECTOR switch to the "Zero Adj. I_b , I_{c3} , I_{c2} " position. Balance the current amplifier by depressing the CURRENT Push-to-Read pushbutton and simultaneously adjust the ZERO ADJUST control (M) so that the meter reads "0".

7. Set the gm/CURRENT SELECTOR switch to the "Read I_b " position, the CURRENT RANGE SELECTOR (N) to the "10 ma" position, and the CURRENT LIMIT switch (R) to the "100 ma" position.

8. Press the CURRENT Push-to-Read pushbutton (L) and slowly increase the plate voltage until the tube fires (starts to conduct). The firing point is indicated by a sudden plate current surge.

9. Release the CURRENT Push-to-Read pushbutton and press the VOLTAGE DROP pushbutton. Read the voltage at which the tube fired on the meter. If the meter pointer deflection is insufficient, set the TUBE DROP VOLTAGE RANGE switch (T) to a lower range. It will be necessary to hold this switch in position while a reading is taken because the switch is spring-loaded to return to the 300-volt range.

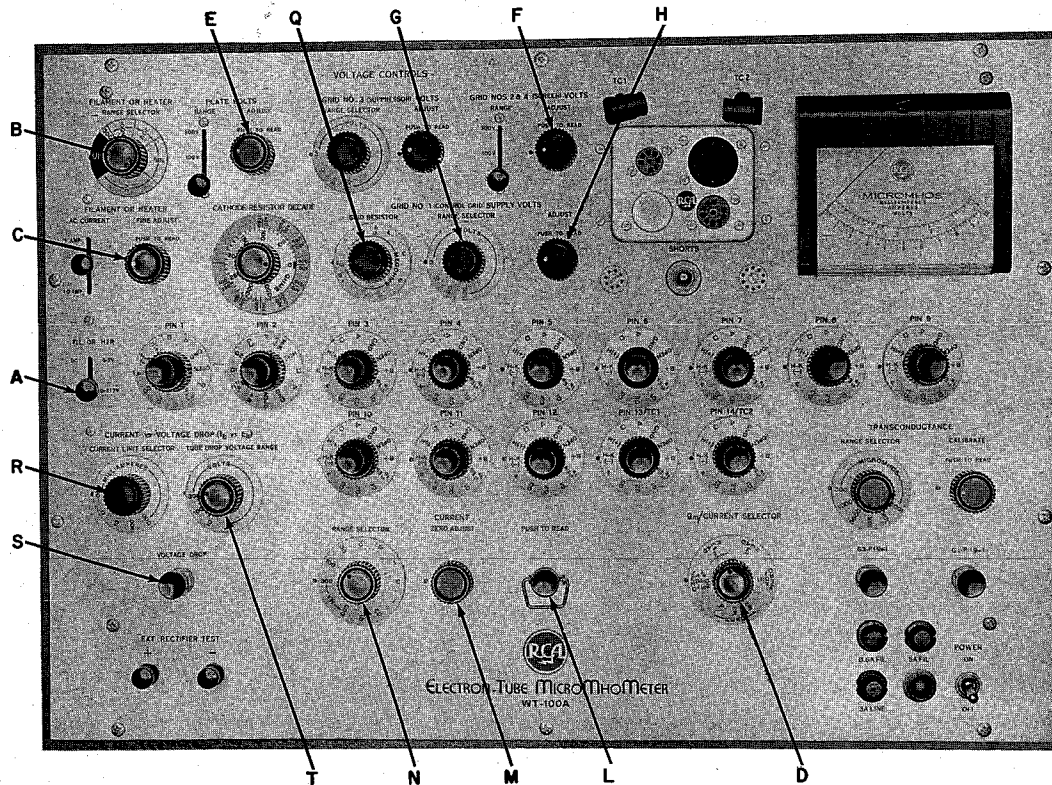

Figure 5. Controls used in testing a 2D21 Thyatron

Method 2

This method is a critical Grid-No. 1 voltage check. The measurement of the value of Grid-No. 1 voltage at which the tube fires is made, for the 2D21, under the following conditions: Heater Voltage (ac), 6.3 volts; Anode Voltage, 165 volts (117 volts rms); Grid-No. 2 Voltage, 0 volts; Grid-No. 1 Voltage, 7 volts (5 volts rms), Grid-No. 1 Resistor, 1 megohm.

Under these conditions, the average value of the Grid-No. 1 voltage at which the tube fires is less than 5 volts. Individual tubes may vary from this value.

Socket Connections: Same as for Method 1.

1. Set the pin switches to correspond to the socket connections. Since Grid-No. 2 is at zero volts, it is returned to the cathode.

- | | |
|----------------|-----------------------|
| Pin 1: G_1 | Pin 5: H-K (-) |
| Pin 2: H-K (-) | Pin 6: I_b vs E_b |
| Pin 3: H (+) | Pin 7: H-K (-) |
| Pin 4: H-K (-) | |

2. Repeat steps 2, 3, 4, and 5 as outlined for Method 1.

3. If no shorts are noted, depress PLATE VOLTS ADJUST (E) and set anode voltage to 165 volts.

4. Set the GRID-NO. 1 (CONTROL GRID) SUPPLY VOLTS RANGE SELECTOR (G) to the "10V" range. Depress the ADJUST control (H) and set to 7 volts.

5. Set the GRID RESISTOR control (Q) to 1 megohm, the CURRENT LIMIT switch (R) to the "100 ma" position, and the CURRENT RANGE SELECTOR (N) to the "100 ma" position.

6. Set the gm/CURRENT SELECTOR switch to the "Zero Adj" " I_b , I_{c3} , I_{c2} " position. Balance the current amplifier by depressing the CURRENT Push-to-Read pushbutton (L) and simultaneously adjust the ZERO ADJUST control (M) so that the meter reads "0".

7. Set the gm/CURRENT SELECTOR switch to the "Read I_b " position.

8. Press the CURRENT Push-to-Read pushbutton and slowly decrease the Grid-No. 1 voltage until the tube fires (starts to conduct). This is indicated by a sudden plate current surge.

9. Release the CURRENT Push-to-Read pushbutton and depress the Grid-No. 1 ADJUST control to read the grid voltage at which the tube fired.

0C2 Voltage Regulator

The 0C2 was chosen as an example for checking voltage regulation. The technique employed for this check is to measure the voltage drop across the tube as the current through the tube is raised. Measurements are made under the conditions outlined in the numbered steps below. Under these conditions, when the current through the tube is varied from 5 to 30 milliamperes the average voltage drop is 75 volts. Individual 0C2 types may have voltage drops from 68 to 83 volts. Within the 5-to-30-milliamperere range the maximum voltage regulation should be 4.5 volts.

Socket Connections:

Pin 1: Anode	Pin 5: Anode
Pin 2: Cathode	Pin 6: Internal Con-
Pin 3: Internal Con-	nection — Do
Not Use	Not Use
Pin 4: Cathode	Pin 7: Cathode

1. Set the pin switches to correspond to the socket connections shown above.

Pin 1: I_b vs E_b	Pin 5: I_b vs E_b
Pin 2: H-K (-)	Pin 6: Open
Pin 3: Open	Pin 7: H-K (-)
Pin 4: H-K (-)	

2. Check for shorts.

3. Set the "CURRENT LIMIT SELECTOR" switch to the "10 MILLIAMPERE" position.

4. Set the "gm/CURRENT SELECTOR" switch to "READ I_b " and follow procedures outlined on pages 10 and 11, "to Measure Electrode Current".

5. Set the "CURRENT/RANGE SELECTOR" switch to "10 MA" then hold the "CURRENT/PUSH TO READ" pushbutton down while slowly increasing the plate voltage until the meter indicates 5 milliamperes.

6. Release the "CURRENT/PUSH TO READ" pushbutton and depress the "VOLTAGE DROP" pushbutton. The meter will indicate the voltage drop across the tube.

7. Set the "CURRENT LIMIT SELECTOR" switch to the "100 MILLIAMPERE" position and the "CURRENT/RANGE SELECTOR" switch to "30 MA".

8. Turn the "PLATE VOLTS" control fully counterclockwise to reduce the plate voltage to zero.

9. Hold the "CURRENT/PUSH TO READ" pushbutton down, and slowly increase the plate voltage from the zero setting until the meter indicates 30 milliamperes.

10. Release the "CURRENT/PUSH TO READ" pushbutton and depress the "VOLTAGE DROP" pushbutton. The meter will indicate the voltage drop across the tube. The difference between the voltage drop at 5 milliamperes and the voltage drop at 30 milliamperes should not exceed 4.5 volts.

Application

In addition to transconductance (G_{1-P} , G_{3-P}), electrode current and voltage-drop measurements, the WT-100A may be used to measure grid-No. 2-to-plate transconductance, contact potential, interelectrode leakage, and currents due to primary grid emission and gas. Plate resistance and the amplification factor of triodes may also be calculated from measurements made with the WT-100A.

Measurement of Screen-to-Plate Transconductance

In some applications in which balance may be a serious problem, such as dc amplifiers, it is helpful to make as many comparison measurements as possible in order to select tube of similar characteristics. While no data are published on screen-to-plate transconduct-

ance, it has been found that this type of measurement is useful as an added test in selecting balanced tubes. In order to utilize this measurement effectively, some criteria of acceptability should be established based on the individual requirements of the circuit designer. It must be remembered however that the screen-to-plate transconductance may vary widely from tube to tube.

The measurement involves the insertion of the oscillator signal to the screen grid while normal bias is kept on Grid No. 1. The only accessory needed is a 2000 ohm $\pm 10\%$, 1-watt resistor. As an example, the procedure for measuring screen-to-plate transconductance of a 6SJ7 under typical operating conditions is as follows. The grid-No. 2-to-plate transconductance is approximately 100.

Socket Connections

Pin 1—Shell	Pin 5—Cathode
Pin 2—Heater	Pin 6—Grid-No. 2
Pin 3—Grid-No. 3	Pin 7—Heater
Pin 4—Grid-No. 1	Pin 8—Plate

1. Set all pin switches, except pins number 4 and 6 to correspond to the socket connections.

Pin 1: Gnd	Pin 5: H-K (—)
Pin 2: H (+)	Pin 6:
Pin 3: H-K (—)	Pin 7: H-K (—)
Pin 4:	Pin 8: P

Since the grid-No. 1 voltage is given as —3 volts and no signal is to appear on grid-No. 1 in this test, the grid-No. 3 voltage can be used to supply the bias.

2. Set pin switch 4 to “G3” and adjust the G3 supply for 3 volts.

3. Set pin switch 6 to “G1”.

4. Dial TC1 (pin switch 13) to “G1”; dial TC2 (pin switch 14) to “G2”.

5. Connect the 2000 ohm resistor between the two top caps TC1 and TC2. Make sure that the resistor is insulated from the chassis. This procedure places the 2000 ohm resistor in series with the screen grid supply and connects the oscillator signal to the screen grid of the tube under test.

6. Turn the grid resistor control to the “5 megohms” position. Since screen-grid voltage will appear across this resistor, it is set to provide maximum resistance to prevent loading of the G2 supply.

7. Insert the tube.

8. Adjust the plate and the grid-No. 2 voltage to 250 volts and 100 volts respectively.

9. Calibrate the transconductance measuring circuit; then press the G1-P button. Read the grid-No. 2-to-plate transconductance directly.

Plate-Resistance (R_p) Measurements

The WT-100A can be used to measure static plate resistance of triodes with accuracy closely approximating that obtainable in a dynamic test. Note that published values of plate resistance are average values based on measurement of a large number of tubes. As a result, R_p for individual tubes of a given type may differ substantially from the published value.

The measurement of plate resistance with the WT-100A is based on the change in plate current produced by a given change in plate voltage when all other electrode voltages remain constant.

1. Set the WT-100A to measure the plate current of the triode under test.

2. Adjust the PLATE VOLTS adjust control for a voltage 10 volts lower than the voltage at which the tube is to be operated.

3. Read and record the plate current.

4. Adjust the PLATE VOLTS adjust control for a voltage 10 volts higher than the voltage at which the tube is to be operated.

5. Read and record the new plate current.

6. The plate resistance of the tube is equal to the total voltage swing in volts divided by the change in plate current in amperes.

$$R_p = \frac{E_b \text{ max} - E_b \text{ min}}{I_b \text{ max} - I_b \text{ min}}$$

Calculation of Amplification Factor

Amplification Factor (mu) may be calculated by multiplying the transconductance in mhos by the plate resistance in ohms.

$$\mu = gm R_p$$

Interelectrode Leakage

Direct measurements of interelectrode leakage currents between any two elements of a tube can be made as follows:

1. Set all dc-voltage controls to their maximum counterclockwise positions.

2. Set the filament or heater voltage to the proper value.

3. Set the pin switches which correspond to the filament or heater according to the tube manufacturer’s basing diagram. Dial all other pin switches to “open”.

4. Set the pin switch which corresponds to one of the electrodes to be checked to the “—H—K” position.

5. Set the pin switch which corresponds to the other electrode to be checked to “P” or “G2” if leakage with respect to a positive voltage is to be measured; or to “G1” or “G3” if leakage with respect to a negative voltage is to be measured. NOTE: When measuring leakage between cathode and grids or plate, use a negative supply only.

6. Set the selected voltage control to obtain the voltage required for the test.

7. Set the gm/CURRENT SELECTOR to the electrode current to be measured, i.e. if in Step 4 the pin switch is set to “P”, then the “PLATE VOLTS” control is used to set the voltage on the electrode, and the gm/CURRENT SELECTOR is set to “Read I_b”.

8. Zero adjust the Current Amplifier. Then, with the gm/CURRENT SELECTOR set to the “Read I_b” position, measure leakage current. (See page 10) NOTE: To measure leakage between one electrode and any combination of other electrodes, set the pin switch corresponding to the one electrode to the “—H—K” position and set the pin switches corresponding to the

other electrodes to the same voltage source, i.e. all to "P". When measuring leakage between cathode and grids or plate, use a negative supply only. Follow steps 6 through 8 given above.

Heater-Cathode Leakage

Direct measurement of heater-cathode leakage, with the cathode either positive or negative, can be made as follows:

1. Set all dc-voltage controls to the maximum counterclockwise position.
2. Set the filament or heater voltage to the proper value.
3. Set the pin switches which correspond to the filament or heater according to the tube manufacturer's basing diagram.
4. Set the pin switch which corresponds to the cathode to "P" or "G2", if leakage with respect to a positive voltage is to be measured; or to "G1" or "G3", if leakage with respect to a negative voltage is to be measured.
5. Set the selected voltage control to obtain the voltage required for the test.
6. Set the gm/CURRENT SELECTOR to the "Zero Adj I_b " position and zero adjust the Current Amplifier. Switch to the "Read I_b " position and measure the leakage current.

Contact (Retarding) Potential

The term "Contact Potential" as generally used refers to the combined effect of two phenomena. Actual contact potential, which makes the grid more positive, is a result of the work function of the materials of which the cathode and grid are composed. The work function is the energy required to remove an electron from the surface of the cathode, and is usually in the order of 1 to 5 volts for most materials used in vacuum tubes. The other component of "contact potential" is due to the initial velocity of the electrons leaving the cathode. Some of these electrons will have sufficient energy to pass from the cathode to the control grid making this grid more negative.

Usually the current due to initial velocity is greater than the current due to the work function. The resulting voltage in the grid circuit is generally referred to as "contact potential". Although the "contact potential" is a combination of the two phenomena described above, it is usually measured as the bias voltage required to reduce grid-No. 1 current to some small value e.g. 0.1 microampere. This bias voltage is called the **Retarding Potential**, and this term which more accurately describes the measurement which is made, will be used in this booklet.

Reverse Grid Current

Gas current, primary grid emission, and leakage currents in a vacuum tube all produce reverse grid current. The presence of reverse grid current tends to reduce the bias voltage on the tube especially in those applications where the value of grid circuit resistance is large. This reduction in bias voltage will result in an increase in transconductance and cathode and plate current.

Gas current is the result of the ionization of gas molecules. The ions thus produced are attracted to the negatively biased grid-No. 1 and produce a current which tends to make this grid more positive. Primary grid emission is a thermal effect produced by the heater and the heat dissipated in the screen grid and the plate. The increased temperature causes the control grid to emit electrons thereby reducing the bias voltage. Similarly, leakage between the grid-No. 1 and a positive electrode produces a current which tends to reduce the bias voltage.

Measurement of Retarding Potential

Retarding Potential is measured as follows:

1. Set the heater or filament to normal operating voltage, and the pin switches corresponding to the cathode and grid-No. 1 of the tube to "-H-K" and "G₁", respectively. All other electrodes are set to "open". Set all regulated electrode voltage controls fully counterclockwise.
2. Normal operation of the instrument results in an upscale reading on the meter for reverse grid current, and a downscale reading for the combined effect of the work function and the current due to initial electron velocity. In order to get an "on scale" reading, set the gm/CURRENT SELECTOR to "ZERO ADJ I_{c_1} ". Set the current RANGE SELECTOR to the ".3 MA" range or higher. Adjust the ZERO ADJUST control to position the meter pointer to the "1" mark on the meter scale.
3. Set the gm/CURRENT SELECTOR to "READ I_{c_1} ".
4. Depress the current Push-to-Read button and simultaneously increase the grid-No. 1 voltage. The meter pointer should approach the "1" mark. Set the current RANGE SELECTOR to progressively lower ranges and adjust the grid-No. 1 voltage until 0.1 microampere is indicated on the meter scale. (0.1 microampere is 1 scale division to the left of the "1" mark when the RANGE SELECTOR is set to ".003 MA".)
5. Release the CURRENT Push-to-Read button, and depress the GRID No. 1 SUPPLY VOLTS ADJUST control and read the Retarding Potential.

Measurement of Reverse Grid Current

Reverse grid current is measured as follows:

1. Set up the instrument as specified under typical operating conditions in the data for the tube under test. If the data for the tube does not provide for at least two volts of bias, two volts of grid voltage should be supplied from the grid-No. 1 supply. Set the GRID No. 1 SUPPLY VOLTS RANGE SELECTOR to a range with a maximum voltage value which can cut the tube off.

2. Set up the instrument to read I_{c_1} .

3. Depress the CURRENT Push-to-Read button. An up-scale reading of the meter pointer indicates reverse grid current. To determine the nature of this current proceed as follows:

4. Increase the bias by quickly turning the Grid-

No. 1 ADJUST control to its maximum clockwise position, so that the tube is cut off. If the meter pointer drops to zero immediately, then the reverse grid current is due to gas.

5. If the meter pointer does not drop to zero or if there is appreciable delay before the position of the pointer changes, then the reverse grid current is due to leakage, grid emission, or a combination of both.

6. Remove the heater voltage by turning the pin switch corresponding to one side of the heater, to the same pin switch position as the other side (i.e. both sides of the heater to either $-H-K$ or $+H$). In general, if the grid current remains constant or fluctuates after a 15-second cooling period, or if the grid current fluctuates rapidly when the tube is tapped, then the grid current is due to leakage.

Circuit Description

Regulated Power Supply

The regulated power supply provides positive plate and screen-grid voltages, negative control-grid and suppressor-grid voltages, and a negative voltage for the gm preamplifier.

An RCA-5U4-GB is used as the rectifier for the plate and screen-grid supply. Regulation of the plate supply is accomplished by means of a degenerative circuit which utilizes an RCA-6DQ5 as a series regulator, and an RCA-6AU6 as a control amplifier. When a tube under test is energized, an additional load is placed on the power supply. The increased current increases the voltage drop across the 5U4GB and the 6DQ5 thereby decreasing the voltage at the cathode of the 6DQ5 (V10). This change in the voltage is applied to the control grid of the 6AU6 (V5) through resistor R2 making the control grid more negative. As a result of the increased bias, the plate current in the 6AU6 decreases and consequently, the plate voltage increases. Because the control-grid of the 6DQ5 is directly coupled to the plate of the 6AU6, the control grid of the 6DQ5 becomes more positive and, as a result, the voltage drop across the 6DQ5 decreases. A decrease in the voltage drop of the 6DQ5 increases the current-handling capability of this tube by an amount that is directly proportional to the load requirement and helps to stabilize the voltage at the cathode.

AC ripple voltage from the rectifier is filtered in a similar manner. The ripple voltage at the plate of (V10) causes a voltage variation, at ripple frequency, at the cathode. This variation in voltage appears on the con-

trol grid of V5, through capacitor C_1 . The plate voltage of V5, which varies inversely as the change in control grid voltage, is 180° out of phase with the ripple voltage at the plate of the 6DQ5 (V10). Because the control grid of V10 is directly coupled to the plate of the 6AU6 (V5), any change in the plate voltage of V5 will cause a corresponding change in the control-grid voltage of V10 to counteract the effect of the ripple voltage.

THE PLATE VOLTS ADJUST is an adjustable resistor in the cathode circuit of V5, the control amplifier. This resistor is not in the feedback circuit. Therefore, any change in resistance value, caused by changing the plate voltage, affects the dc operating characteristics of V5, but not the ac gain. As a result, ripple voltage is held to a low value at any plate voltage setting.

V6, an RCA-6CL6, and V7, the pentode section of an RCA-6U8 are used in the screen voltage supply. The operation of this circuit is identical with that of the plate supply circuit.

The negative voltage supply for the control grid, the suppressor grid circuits and for the instrument's gm preamplifier utilizes an RCA-6X4 rectifier, and an RCA-OA2 voltage regulator. Full-wave rectified negative dc voltage is obtained by use of a grounded-cathode circuit utilizing the RCA-6X4.

Current Amplifier

The Current Amplifier provides the wide range of current measurements which may be made with the WT-100A, and in addition protects the meter from damage should there be a severe overload. This circuit

utilizes a 12AU7 in a conventional balanced-bridge circuit of the VoltOhmyst* type. The sensitivity of the amplifier has been increased so that the voltage required for full-scale deflection of the meter pointer is 0.5 volt. The increased sensitivity prevents excessive voltage drop across the shunts, which are in series with the power supply.

A separate power supply which utilizes a selenium rectifier, and a specially-designed electrostatically shielded power transformer is used to isolate the Current Amplifier from ac circuits. As a result the entire circuit is isolated from the instrument ground. This feature permits an upscale reading for all currents which normally must be measured.

gm Preamplifier

The gm Preamplifier is a two-stage feedback amplifier with a balanced-bridge output circuit. The amplifier has a bandpass of 15 to 150 kc, and has sufficient feedback to the cathode of the pentode section of the 6U8 (V9) to insure better than one percent linearity for both the preamplifier and the meter. The gm preamplifier requires an input of approximately 0.005 volt to provide full-scale deflection on the meter.

The supply voltage for the preamplifier is taken from the OA2. The grounded-plate, negative-cathode circuit eliminates the need for an additional fixed positive voltage supply and permits bypassing the gm preamplifier to the B+ bus. This circuit arrangement tends to eliminate power supply ripple which would be present in the input circuit if the gm preamplifier was bypassed to ground. In addition, any ripple voltage which may be present in the plate circuit of the tube under test due to low plate resistance, is attenuated by the bandpass characteristics of the preamplifier by a factor of better than 50 db.

The use of a balanced-bridge output circuit insures extremely good linearity of the circuit since the ac load on each crystal diode in the bridge circuit is equal.

Transconductance Test Circuit

Figure 6 shows a simplified schematic of the transconductance measuring and calibrating circuits. These circuits include the tube under test, oscillator, precision voltage-divider network, a plate load resistor, and the gm preamplifier and meter.

The value of the plate load resistor (R_L) was chosen to be very small in comparison with the values of plate resistance found in most tube types. In the 100K, 30K, 10K, and 3000 micromhos ranges the resistor (R_L) is 10 ohms. In the 1000- and 300-micromhos ranges, the resistor is 50 ohms and 166 ohms, respectively.

When the transconductance range selector is switched from one range to another, the amplitude of the oscil-

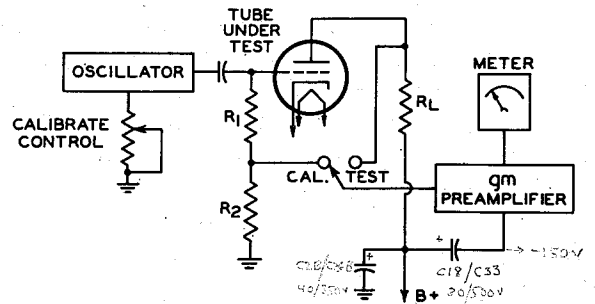

Figure 6. Simplified diagram of transconductance calibrating and measuring circuits

lator signal is automatically changed. This design feature permits the use of low values of plate-load resistor to insure accurate measurements of tubes having low values of plate resistance.

The following tabulation lists the approximate signal voltage applied to grid-No. 1 of the tube under test for each position of the transconductance range switch.

<u>gm Range Switch Position</u>	<u>Approx. Oscillator Signal Voltage</u>
100K	0.005 volt
30K	0.017 volt
10K	0.056 volt
3K	0.17 volt
1K	0.11 volt
300	0.11 volt

In order to keep the oscillator signal voltage relatively low and thus maintain linearity and sensitivity, the values of the plate-load resistor and the oscillator signal voltage are changed for the 1000- and 300-micromhos ranges.

To obtain full-scale deflection on the meter, the gm pre-amplifier requires an input of approximately 0.005 volt. During the transconductance calibrate adjustment, the gm preamplifier is connected across R_2 and the CALIBRATE control, which sets the level of the oscillator signal voltage, is adjusted for full-scale deflection of the meter pointer. R_1 and R_2 constitute a voltage-divider network with R_2 having the same value as R_L .

During the transconductance measurement operation the gm preamplifier is connected across R_L . The oscillator signal voltage required to produce 0.005 volt across R_2 is applied to the grid of the tube under test. If the ac signal current produces a voltage of 0.005 volt across R_L , then the tube under test has a gm equal to the full scale value of the meter. If a value less than 0.005 volt appears across R_L , then the measured value of transconductance will be proportionally less than the full scale value.

*Trade Mark "VoltOhmyst" Reg. U. S. Pat. Off.

During calibration, the tube under test is operating with ac current, produced by the oscillator signal, in the plate circuit. If the meter pointer is set to full scale, by means of the CALIBRATE control, the loading effect of the tube, and any change in component value or in the sensitivity of the gm preamplifier, is automatically cancelled out.

I_b vs E_b

The I_b vs E_b position on the pin switches connects a resistor in series with the low impedance B+ supply and the anode of the device under test. This pin switch position therefore permits testing low-impedance tubes such as rectifiers and gas-filled tubes, without damage to the tubes due to excess current. The value of the

series resistor changes on each range of the CURRENT LIMIT SELECTOR switch. The tabulation given below lists the value of the resistor for each range.

<i>Range</i>	<i>Resistance</i>
0-3 MA	82K
0-10 MA	40K
0-100 MA	2K
0-300 MA	—

When the VOLTAGE DROP pushbutton is depressed, the meter indicates the voltage between the cathode and the anode of the device under test.

Maintenance

General

The WT-100A Electron-Tube MicroMhoMeter is manufactured, tested, and calibrated under strict engineering supervision. If the instrument should require adjustment or repairs, the procedures outlined below should be followed.

A schematic diagram of the WT-100A is attached to the inside back cover of this booklet. If it becomes necessary to replace any of the component parts, only RCA replacement parts or their equivalents should be used. When ordering replacement parts, consult the Replacement Parts List on page 28 and specify the code and serial numbers of the instrument as well as the stock number of the replacement part.

Before proceeding with any adjustment or repair, make sure that the user has operated the instrument properly. Check the operation of the instrument with tubes whose characteristics have been previously recorded. It is advisable to keep several such tubes for use as standards. Check several standard tubes for grid—plate transconductance. Follow the steps outlined in this instruction booklet. Make sure that the CATHODE RESISTOR control is set to the proper value. Check the position of the GRID RESISTOR control; the “gm” position on this control is the maximum counter-clockwise position. When electrode currents measurements of the standard tube are made, make sure the Current Amplifier is balanced, and the gm/CURRENT SELECTOR is in the correct position for the type of measurement being made.

In many cases it may be possible to localize the difficulty by means of an operating check. For example: If the instrument is operative on the current-measuring functions and is inoperative when gm measurements

are made, trouble may be found in the oscillator, gm preamplifier, or the gm calibrate circuits. If the transconductance circuits are operative and current measurements cannot be made, the trouble may be found in the current amplifier and its associated circuit.

The instrument may be removed from the case by removing the 10 screws from the top panel and the two screws from the back of the case. Lift the instrument from the case.

With the instrument removed from the case, inspect the section which is suspected of being inoperative. If the trouble is not located by a visual inspection, take voltage readings and compare them with the voltages given on the schematic diagram. For these measurements the ac line voltage should be held at 117 volts, 60 cps.

Tube Replacement

With the exception of the 12AU7 any tube in the instrument can be directly replaced. If the 12AU7 requires replacement, the current amplifier must be recalibrated.

1. Insert a 12AU7 which has been aged for 12 hours under the following conditions: rated heater voltage, 115 volts dc plate voltage and with grid tied to cathode and the cathode grounded.

2. Set R191 to the center of its range. Allow tube to heat for 15 min.

3. Set the gm/CURRENT SELECTOR switch to “Read I_b ”.

4. Set the CURRENT Zero Adjust control fully clockwise. Depress the CURRENT Push to Read button. Adjust R191 so that a reading of “4” is indicated on the 0-10 scale of the meter.

5. Proceed with the calibration of the current amplifier.

Calibration of the Current Amplifier

The current amplifier may be checked for calibration, and adjusted against a standard milliammeter. This meter should have an accuracy of 0.5%, over a range from 0.05 to 500 milliamperes.

1. Set the PLATE VOLTS control to its maximum counter-clockwise position, and set the CATHODE RESISTOR control to the 350-ohm position.

2. Balance the CURRENT AMPLIFIER, and then set gm/CURRENT SELECTOR to the "Read I_b " position. Set the CURRENT RANGE SELECTOR switch to the "300 ma" position.

3. Connect the milliammeter to the "EXT RECTIFIER TEST" binding posts. Set the milliammeter to the 0-500 MA range.

4. Depress the CURRENT Push-to-Read button, set the PLATE VOLTS RANGE lever-action switch to the required range, and slowly increase the plate voltage by rotating the PLATE VOLTS ADJUST clockwise, until 150 milliamperes is indicated on the external meter. If the meter on the WT-100A is not within 2% of 150 milliamperes, adjust R114 in the cathode circuit of the 12AU7 Current Amplifier so that the meter reads 150 milliamperes.

5. Similarly, check the "100 ma", "30 ma", and "10 ma" ranges at half-scale current values. Check the values of the precision resistors in the ranges below 10 ma.

6. If the meter indication is not correct or if the instrument is inoperative on one range but is correct on the others, check the value of the resistors R98—R108 with a wheatstone bridge.

Shorts Test Circuit Check

The Shorts Test circuit may be checked for operation as follows:

1. Set the FILAMENT or HEATER RANGE SELECTOR to "off".

2. Remove the Multiple-Socket Plug-in Unit from the receptacle.

3. Connect a one-megohm resistor from pin 1 on the socket connector to ground. Depress Pin Switch 1. The shorts indicator should glow.

4. Repeat the procedure in step 3 for each of the other pins (2 through 14). TC1 and TC2 are connected to pin numbers 13 and 14 respectively. Pins number 15 and 16 are not used.

Transconductance (gm) Circuit Check

The calibration accuracy affecting transconductance (gm) measurement depends primarily upon the ratio

of the transconductance circuit plate load to the grid resistance values as selected by the TRANSDUCTANCE RANGE SELECTOR switch (S49); and on the ac impedance of the electrolytic capacitors C2A, C2B, and C18 at a frequency of approximately 45 kcs, which is the gm measurement signal frequency. Normally, this circuit should not require recalibration, however, proper operation of the gm measurement circuit may be checked as follows:

Equipment required for recalibration includes an ac voltmeter, such as the RCA WV-74A or equivalent; an audio frequency generator capable of generating an undistorted sinewave signal of approximately 45 kcs, such as the RCA WA-44C or equivalent; the following resistors with values of: 10 ohms (R_A), 50 ohms (R_B), 166 ohms (R_C), 323 ohms, and 950 ohms, each having a tolerance of $\pm 1\%$ and a $\frac{1}{2}$ -watt dissipation; a 2200-ohm $\pm 10\%$ $\frac{1}{2}$ -watt resistor (R_D); and a 4-position single-circuit switch (S_{Ext}). The test switch must be of high quality and have a very low contact resistance. The 2200-ohm series resistor (R_D) reduces the shunting effect of the externally connected audio generator to a negligible value. Note, the following calibration procedures do not require a tube under test. Before proceeding with the calibration construct the test circuit as shown in Fig. 7.

Plate-Load Resistance Check

To properly calibrate the transconductance (gm) measurement circuit of the WT-100A it will be necessary to disconnect the reactive component (L68), which is in parallel with the plate load resistors; thus for test purposes the plate load (R_L) is purely resistive. A simplified diagram of this circuit is shown in Fig. 6. The test setup for measurement of R_L is shown schematically in Fig. 7. The plate load is one of three values of resistance (R_{LA} , R_{LB} , R_{LC}) in the gm measurement circuit and is selected by the TRANSDUCTANCE RANGE SELECTOR switch on the WT-100A instrument panel. The effective resistance of these plate load resistors may be determined as follows:

1. With power switch in the "OFF" position rotate the PLATE VOLTS control fully counterclockwise.

2. Set PIN 13/TC1 pin switch to "B+" position, ground top cap TC1 to WT-100A chassis and set PIN 14/TC2 pin switch to "P" position. Connect top cap TC2 to position No. 1 of external switch.

3. Set the external test switch to position No. 1 as shown in Fig. 7 and the TRANSDUCTANCE RANGE SELECTOR switch to the 3000-micromho range. Set the WV-74A (ac voltmeter) for 0.03 volts full scale and the audio generator to provide a fre-

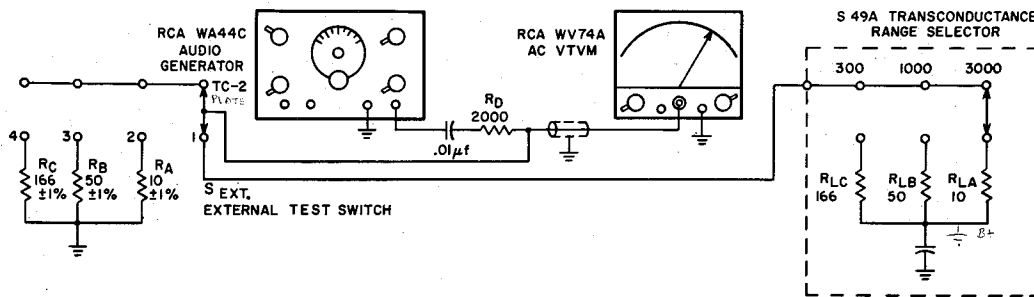

Figure 7. Test setup for determining the plate load resistance.

quency of approximately 45 kcs with the attenuator set for a maximum sine-wave output. Do not disturb the setting of the WA-44C during the remainder of the test. Record the voltage reading across R_{LA} for the 3000-micromho range as indicated on the ac voltmeter.

Set the external test switch to the No. 2 position. Record the voltage drop across R_A . The ac voltage drop across R_{LA} (E_{LA}) and R_A (E_A) will be equal if the resistance values of R_{LA} and R_A are equal. The effective plate load resistance equals $E_{LA}/E_A \times 10$ ohms for the 3000-micromho and higher ranges.

4. Set the TRANSDUCTANCE RANGE SELECTOR switch to the 1000-micromho range and the external test switch to position No. 1. Record the voltage developed across R_{LB} as indicated on the voltmeter. Set the external test switch to the No. 3 position. Record the voltage drop across R_B . The voltage drops across R_{LB} (E_{LB}) and R_B (E_B) will be equal if the resistances are equal. The effective plate load resistance equals $E_{LB}/E_B \times 50$ ohms for the 1000-micromho range.

5. Set the WV-74A range switch to the 1-volt full scale position. Set the TRANSDUCTANCE RANGE SELECTOR switch to the 300-micromho range and the external test switch to position No. 1. Record the voltage drop across R_{LC} . Set the external test switch to the No. 4 position. Record the voltage drop across R_C . The ac voltage drops across R_{LC} (E_{LC}) and R_C (E_C) will be equal if the resistances are equal. The effective plate load resistance equals $E_{LC}/E_C \times 166$ ohms for the 300-micromho range.

6. The allowable tolerance for the tests described in the preceding steps should be within $\pm 1\%$ of the effective load value for each micromho range. Higher values than these tolerances indicate a possible defect in S49A, S48C, C2B, C18, R151, R143, or R144. Lower values than these tolerances usually indicate a defect in R151, R143, or R144. Following the plate circuit resistance check, remove all external connections to the WT-100A and reconnect the choke (L68) to its original circuit.

Grid-Circuit Resistance Check

To check the grid-circuit resistance in the gm measurement circuit of the WT-100A, proceed as follows:

1. Rotate the PLATE VOLTS control *fully counter-clockwise*.

Note — Do not change setting of the PLATE VOLTS control during this measurement.

2. Set the PIN 13/TC1 pin switch to the "B+" position, ground top cap TC1 to the WT-100A chassis and throw POWER switch to "ON".

3. Set gm/CURRENT SELECTOR to "READ gm" and the TRANSDUCTANCE RANGE SELECTOR switch to 1000-micromho range.

4. Set PIN 14/TC2 pin switch to "P" position and PIN 8 pin switch to "G1" position.

5. With the ac voltmeter set for 1 volt full scale, connect the probes from pin No. 8 of octal test socket on WT-100A to ground.

6. Depress TRANSDUCTANCE CALIBRATE switch and adjust for full scale reading on WT-100A meter. Measure the ac grid voltage on the voltmeter. Release TRANSDUCTANCE CALIBRATE switch.

7. Connect the signal lead of the audio generator in series with the external 950-ohm resistor to top cap TC2 and the ground lead to top cap TC1. Set the generator for approximately 45 kc with the attenuator in the SINE X1 position. Depress G₁-P(gm) push-button and adjust the generator output control for full-scale reading on the WT-100A meter. Remove the voltmeter probes from the octal test socket and ground; and connect the probes directly across the audio generator output terminals (observe proper polarity). If the reading taken across the terminals differs from the reading obtained in step 6 by more than $\pm 2\%$, one or more of the multiplier resistors, R134 through R140, may be defective.

8. Substitute a 323-ohm resistor for the 950-ohm resistor, set the controls to the 3000-micromho and SINE X10 positions, and repeat steps 6 and 7.

Cathode-Circuit Impedance Check

To avoid gm measurement errors, the 40 μ f cathode by-pass capacitor (C2A) must have a low impedance value at 45 kc to avoid appreciable degeneration in the gm test circuit. The cathode-circuit impedance may be checked as follows:

1. Select a beam power tube such as an RCA-6L6-GC and set up test conditions to provide the "Typical Operation" values as listed in the RCA Receiving Tube Manual (RC-20). Set the WT-100A CATHODE RESISTOR DECADE control to provide recommended bias resistance. Rotate GRID No. 1 (CONTROL GRID) SUPPLY VOLTS ADJUST control to minimum position and set GRID RESISTOR switch to "gm" position. Read and record the plate current and the Transconductance as described in the section "Operation".

2. Turn CATHODE RESISTOR DECADE control to zero position, set GRID No. 1 (CONTROL GRID) SUPPLY VOLTS RANGE SELECTOR switch and ADJUST control to approximate the operating grid voltage listed in the RCA Receiving Tube Manual. Note: GRID RESISTOR switch must be in "gm" position.

3. Set gm/CURRENT SELECTOR switch to "ZERO I_b " position, depress CURRENT PUSH TO READ pushbutton and adjust CURRENT ZERO ADJUST to zero as indicated on WT-100A meter.

4. Set gm/CURRENT SELECTOR switch to "Read I_b " position, depress PUSH TO READ pushbutton and adjust GRID No. 1 SUPPLY VOLTS ADJUST control to provide same I_b reading as that obtained in step 1. Release PUSH TO READ pushbutton.

5. Set gm/CURRENT SELECTOR switch to "READ gm" position, depress TRANSCONDUCTANCE CALIBRATE control and adjust for full scale reading on WT-100A meter. Release CALIBRATE control and depress G1-P (gm) pushbutton. The gm reading observed should be the same as noted in step No. 3. If the reading is lower, the impedance of the 40 μ f capacitor, C2A at 45 kc is sufficient to introduce a degree of degeneration which will affect the accuracy of the gm measurement test. In such cases, replacement of C2A may be necessary.

Screen-Grid-Circuit Impedance Check

The impedance of the screen-grid circuit is such that a slight increase in the impedance of screen by-pass capacitor (C2C) will produce negligible error in the gm measurement test.

Oscillator Circuit Check

The following check should be performed if the oscillator is suspected of being defective and when a com-

ponent in the oscillator circuit is replaced.

1. Set pin switch 13 to "G1" and pin switch 14 to "Gnd." Connect an oscilloscope between the two top caps. Make sure that the Grid No. 1 ADJUST control is set fully counterclockwise and that the GRID RESISTOR control is set to the "gm" position. The observed sine wave should be symmetrical with respect to the axis, and free from high-frequency bursts. The waveform should remain symmetrical as the TRANSCONDUCTANCE CALIBRATE control is rotated, over its entire range.

If distortion or high-frequency bursts are observed, remove the instrument from the case and check the components in the oscillator circuit.

2. Depress and rotate the CALIBRATE control. It should be possible to obtain at least full-scale deflection on the meter with the CALIBRATE control fully clockwise, and at least half-scale deflection with the CALIBRATE control fully counterclockwise. If deflection of the meter pointer does not meet these conditions, vary the slug in the oscillator coil until the desired reading is obtained.

AC Heater Current Calibration

1. With the WT-100A set-up for ac-heater operation set TC1 to H(+) and TC2 to H-K(-). Connect a standard ac ammeter, which has 0-1 and 0-10 ampere ranges, between TC1 and TC2.

2. Adjust the heater voltage so that the standard meter reads exactly 1 ampere on the 1 ampere range.

3. Depress the FILAMENT or HEATER FINE ADJUST and simultaneously hold the AC CURRENT 1 AMP-10 AMP switch in the "1 AMP" position. The meter pointer on the WT-100A should deflect to full scale. If it does not, it will be necessary to recalibrate the ac-heater current circuit.

4. Adjust R67 and R171, located on the power-supply chassis, for full scale deflection of the meter.

5. Reduce the current to 0.3 ampere on the standard meter. The meter on the WT-100A should indicate 0.3 ampere $\pm 3\%$. If the reading obtained is outside the specified tolerance, adjust R171 to obtain a reading approximately one-half scale division on the other side of the 0.3 ampere reading obtained previously.

6. Increase the current to 1.0 ampere on the standard meter and readjust R67 to obtain full scale deflection on the WT-100A meter. Repeat steps 5 and 6.

7. Set the standard ac ammeter to the 10-ampere range, and increase the heater voltage until the meter reads exactly 5 amperes.

8. Adjust R172 located on the power-supply chassis so that the meter on the WT-100A indicates 5 amperes on the 10-ampere range. The meter should be within $\pm 3\%$ at full-scale reading.

Replacement Parts List

Type WT-100A

When ordering replacement parts, include serial number and code number of instrument.
Parts should be ordered through a local RCA tube and parts distributor.

Symbol No.	Description	Stock No.	Symbol No.	Description	Stock No.
	Capacitors				
C1	Paper: 0.047 μf $\pm 20\%$, 600 volts...	73592	R2	Composition: 9320 ohm $\pm 1\%$, $\frac{1}{2}$ watt.....	209844
C2A C2B			R3	Wire wound: 40,000 ohm $\pm 10\%$, 10 watt.....	209625
C2C	Electrolytic: 40/40/40 μf , 350/350/150 volts.....	209572	R4	Composition: 100,000 ohm $\pm 1\%$, $\frac{1}{2}$ watt.....	209649
C6	Electrolytic: 3000 μf , 10 volts.....	209573	R5	Wire wound: 2000 ohm $\pm 10\%$, 10 watt.....	34473
C7	Electrolytic: 40 μf , 500 volts.....	209568	R6	Composition: 1 megohm $\pm 1\%$, $\frac{1}{2}$ watt.....	208022
C8 C9	Same as C1		R7 to R9	Composition: 3 megohm $\pm 1\%$, $\frac{1}{2}$ watt.....	209646
C10	Electrolytic: 40 μf , 500 volts.....	209568	R10 R11	Composition: 680 ohm $\pm 20\%$, $\frac{1}{2}$ watt.....	
C11	Paper: 0.27 μf $\pm 10\%$, 400 volts.....		R12 to R25 incl.	Composition: 47 ohm $\pm 10\%$, $\frac{1}{2}$ watt.....	
C12 C13	Mica: 3300 μmf $\pm 20\%$, 500 volts.....	39664	R26	Composition: 1.5 megohm $\pm 20\%$, $\frac{1}{2}$ watt.....	
C14	Electrolytic: 20 μf , 250 volts.....	209570	R27	Part of XI-1	
C15	Electrolytic: 15 μf , 250 volts.....	209569	R28	Composition: 22,000 ohm $\pm 5\%$, $\frac{1}{2}$ watt.....	
C16	Ceramic: 0.006 μf $\pm 20\%$, 500 volts.....	210764	R29	Composition: 120,000 ohm $\pm 5\%$, $\frac{1}{2}$ watt.....	
C17	Ceramic: 0.001 μf $\pm 20\%$, 500 volts.....	78623	R30	Composition: 270,000 ohm $\pm 5\%$, $\frac{1}{2}$ watt.....	502427
C18	Electrolytic: 20 μf , 500 volts.....	209571	R31	Composition: 390,000 ohm $\pm 5\%$, $\frac{1}{2}$ watt.....	
C19 \rightarrow C32	Paper: 0.1 μf $\pm 20\%$, 600 volts.....		R32	Variable: 50,000 ohm, 3 watt.....	209264
C20 to C22			R33	Composition: 2000 ohm $\pm 5\%$, $\frac{1}{2}$ watt.....	
C22	Ceramic: 560 μmf $\pm 10\%$, 500 volts.....	76685	R34	Same as R6	
C23	Mica: 6800 μmf $\pm 20\%$, 500 volts.....	39668	R35	Composition: 300,000 ohm $\pm 1\%$, $\frac{1}{2}$ watt.....	209643
C24	Same as C11		R36	Same as R4	
C25	Ceramic: 5 μmf $\pm 5\%$, 500 volts.....	77688	R37	Composition: 29,300 ohm $\pm 1\%$, $\frac{1}{2}$ watt.....	209650
C26, A, B, C	Capacitor 40-40-40 μf , 350 volts.....	216828	R38	Same as R28	
C27, C28	Capacitor 80-80 μf , 350 volts.....	218304	R39	Same as R29	
C30	Capacitor, .27 μf , 200 volts, paper... ..	73786	R40	Same as R30	
C31	Capacitor, 0.047 μf , $\pm 20\%$, 600 volts.....	73599	R41	Same as R31	
C33	Capacitor, 20 μf , 500 volts.....	217626	R42	Same as R32	
C34	Capacitor, .02 μf , 500 volts.....	99585	R43	Same as R33	
C35	Capacitor, 4700 μmf , $\pm 20\%$, 600 volts.....		R44	Same as R6	
C36	Capacitor, 4700 μmf , $\pm 20\%$, 600 volts.....		R45	Same as R35	
CR1	Rectifier: crystal diode.....	76675	R46	Same as R4	
CR2	Rectifier- selenium, bridge.....	103258	R47	Same as R37	
CR3, CR4	Same as CR1		R48	Variable, wire wound: 350 ohm, 25 watt.....	209261
CR5	Rectifier: selenium, half-wave.....	209597	R49 R50	Composition: 47,000 ohm $\pm 20\%$, 2 watt.....	522347
CR6, CR7	Same as CR1		R51	Variable: 5 megohm, 2 watt.....	206045
CR9	Diode, Zener.....	221438	R66	Variable: 125 ohm, 25 watt.....	209265
E1, E2	Binding: post.....	46907	R67	Variable: 500 ohm, $\frac{1}{4}$ watt.....	210704
F1	3 amp., 125 volts, slow blow fuse.....	99164	R71	Composition: 1.31 megohm $\pm 1\%$, $\frac{1}{2}$ watt.....	209645
F2	Fuse: 0.4 amp., 125 volts, time lag ..	211535			
F3	Fuse, 5.0 amp., time lag.....	94802			
F4	Fuse, 0.6 amp., time lag.....	212327			
I1	Neon lamp.....	101857			
I2	Pilot lamp, 4.5 volt.....	11891			
J1	Connector: 16 contact, female.....	209671			
L1 to L16 incl.	Core: lead shielding bead.....	209846			
L17	Coil: oscillator assembly.....	209588			
L19, L20	Choke, RFC, 2.5 mh.....	16612			
L21 through L66	Ferrite cores.....	209846			
L68	Choke, 150 mh.....	221439			
M1	Meter: 0-100 microamp.....	209592			
PJ	Cord: power input.....	70392			
	Resistors				
R1	Composition: 82,000 ohm $\pm 10\%$, 1 watt.....	512382			

Symbol No.	Description	Stock No.
R72	Composition: 436,000 ohm $\pm 1\%$, $\frac{1}{2}$ watt	209644
R73	Composition: 127,000 ohm $\pm 1\%$, $\frac{1}{2}$ watt	209641
R74	Composition: 40,700 ohm $\pm 1\%$, $\frac{1}{2}$ watt	209639
R75	Composition: 10,000 ohm $\pm 1\%$, $\frac{1}{2}$ watt	209648
R76	Composition: 100 ohm $\pm 10\%$, $\frac{1}{2}$ watt	
R78	Composition: 1680 ohm $\pm 1\%$, $\frac{1}{2}$ watt	209651
R79	Composition: 10 megohm $\pm 5\%$, $\frac{1}{2}$ watt	
R80	Same as R30	
R81	Composition: 68,000 ohm $\pm 5\%$, $\frac{1}{2}$ watt	
R82	Composition: 120 ohm $\pm 5\%$, $\frac{1}{2}$ watt	
R83	Composition: 470,000 ohm $\pm 5\%$, $\frac{1}{2}$ watt	
R84	Same as R79	
R85	Same as R83	
R86	Composition: 560,000 ohm $\pm 5\%$, $\frac{1}{2}$ watt	
R87	Same as R81	
R88	Composition: 75,000 ohm $\pm 5\%$, $\frac{1}{2}$ watt	
R89	Same as R29	
R90	Wire wound: 25,000 ohm $\pm 10\%$, 10 watt	28414
R91	Wire wound: 5000 ohm $\pm 10\%$, 10 watt	50854
R92	Composition: 18,000 ohm $\pm 5\%$, $\frac{1}{2}$ watt	502318
R93	Same as R32	
R94	Same as R88	
R95	Same as R32	
R96	Composition: 27,000 ohm $\pm 5\%$, $\frac{1}{2}$ watt	
R97	Composition: 33,000 ohm $\pm 5\%$, $\frac{1}{2}$ watt	
R98	Composition: 166,000 ohm $\pm 1\%$, $\frac{1}{2}$ watt	209642
R99	Composition: 50,000 ohm $\pm 1\%$, $\frac{1}{2}$ watt	209640
R100	Composition: 16,700 ohm $\pm 1\%$, $\frac{1}{2}$ watt	209638
R101	Composition: 5000 ohm $\pm 1\%$, $\frac{1}{2}$ watt	209637
R102	Composition: 1670 ohm $\pm 1\%$, $\frac{1}{2}$ watt	209636
R103	Composition: 500 ohm $\pm 1\%$, $\frac{1}{2}$ watt	209633
R104	Composition: 167 ohm $\pm 1\%$, $\frac{1}{2}$ watt	209631
R105	Composition: 50 ohm $\pm 1\%$, 2 watts	221440
R106	Wire wound: 16.6 ohm $\pm 1\%$, 2 watts	221441
R107	Wire wound: 5.0 ohm $\pm 1\%$, 1 watt	209566
R108	Wire wound: 1.66 ohm $\pm 1\%$, 1 watt	209565
R109	Composition: 3.3 megohm $\pm 20\%$, $\frac{1}{2}$ watt	
R110	Same as R33	
R111	Same as R97	
R112	Variable: 5000 ohm, 2 watt	208677
R113	Same as R97	
R114	Variable: 7500 ohm, $\frac{1}{4}$ watt	209262
R115	Same as R109	
R116	Composition: 47,000 ohm $\pm 20\%$, $\frac{1}{2}$ watt	
R117	Same as R33	
R118	Composition: 56,000 ohm $\pm 10\%$, $\frac{1}{2}$ watt	

Symbol No.	Description	Stock No.
R119	Same as R116	
R120	Composition: 18,000 ohm $\pm 10\%$, $\frac{1}{2}$ watt	
R121	Composition: 47 ohm $\pm 5\%$, $\frac{1}{2}$ watt	
R122	Composition: 27 ohm $\pm 5\%$, $\frac{1}{2}$ watt	
R123	Composition: 82,000 ohm $\pm 10\%$, $\frac{1}{2}$ watt	
R124	Same as R30	
R125	Same as R86	
R126	Composition: 15,000 ohm $\pm 10\%$, 1 watt	
R127	Composition: 56 ohm $\pm 5\%$, $\frac{1}{2}$ watt	
R128	Composition: 1000 ohm $\pm 5\%$, $\frac{1}{2}$ watt	
R129		
R130		
R131	Composition: 8200 ohm $\pm 5\%$, $\frac{1}{2}$ watt	
R132	Variable: 10,000 ohm, 3 watts, pot., w.w.	209263
R133	Composition: 12,000 ohm $\pm 10\%$, $\frac{1}{2}$ watt	
R134	Composition: 950 ohm $\pm 1\%$, $\frac{1}{2}$ watt	209635
R135	Same as R105	
R136	Composition: 667 ohm $\pm 1\%$, $\frac{1}{2}$ watt	209634
R137	Composition: 233 ohm $\pm 1\%$, $\frac{1}{2}$ watt	209632
R138	Composition: 66.8 ohm $\pm 1\%$, $\frac{1}{2}$ watt	209629
R139	Composition: 23.3 ohm $\pm 1\%$, $\frac{1}{2}$ watt	209627
R140	Composition: 10 ohm $\pm 1\%$, $\frac{1}{2}$ watt	210763
R143	Composition: 71.5 ohm $\pm 1\%$, $\frac{1}{2}$ watt	209647
R144	Wire wound: 10.60 ohm $\pm 1\%$, 1 watt	209564
R145	Composition: 27,600 ohm $\pm 1\%$, $\frac{1}{2}$ watt	210867
R146	Composition: 1000 ohm $\pm 5\%$, $\frac{1}{2}$ watt	
R147	Variable: 7500 ohm $\pm 20\%$, 2 watts	211424
R148	Composition: 10,000 ohm $\pm 5\%$, $\frac{1}{2}$ watt	
R149	Same as R96	
R150	Variable: 50,000 ohm $\pm 20\%$, $\frac{1}{4}$ watt	211162
R151	Non-inductive: 166 ohm $\pm 1\%$, 1 watt, w.w.	221442
R152	Same as R82	
R153	Wire wound: 30,000 ohm $\pm 5\%$, 10 watts	55189
R154	Variable: 6 ohm $\pm 20\%$, 2 watts, w.w.	212089
R155	Composition: 1 megohm $\pm 10\%$, $\frac{1}{2}$ watt	
R156	through	
R164	Resistor, 250 ohms, 10%, 7 watt, w.w.	79377
R165	Potentiometer, 350 ohms	217666
R167	Resistor, 39.2 K, 1%, $\frac{1}{2}$ watt	206017
R171	Potentiometer, 5 K, 2 watt	55887
R172	Potentiometer, 2 K, $\pm 20\%$, $\frac{1}{4}$ watt	205193
R175	Potentiometer, 100 K, $\pm 20\%$, $\frac{1}{4}$ watt	204494
R176	Potentiometer, 15 K, $\pm 20\%$, $\frac{1}{4}$ watt	217668
R178	Resistor, 3500 ohms, 10 watt	47344
R179, R185	Resistor, 300 K, $\frac{1}{2}$ watt, 1%	209643
R183	Potentiometer, 10 K	59533
R186, R194	Resistor, 1 megohm, $\frac{1}{2}$ watt, 1%	208022
R191	Potentiometer, 6 ohm, 2 watt	212089

Symbol No.	Description	Stock No.
R192A, B	Composition: 10 ohm $\pm 5\%$, $\frac{1}{2}$ watt	
R195	Composition: 150 ohm $\pm 10\%$, $\frac{1}{2}$ watt	
R196	Composition: 470,000 ohm $\pm 10\%$, $\frac{1}{2}$ watt	
Switches		
S1	Rotary: 5 position, 1 section	209252
S2	Rotary: 4 position, 1 section	209253
S3	Push button: 4 P.D.T., $\frac{1}{16}$ " lg. shaft	209260
S4 S5 S6 S7	Push button: 4 P.D.T., $\frac{3}{8}$ " lg. shaft	209259
S8 S9	Same as S3	
S10	Same as S4	
S11	Same as S3	
S12 to S25	Push button: D.P.D.T.	209258
S26 S27	Rotary: 4 position, 2 section	209251
S28	Rotary: 7 position, 7 section	209257
S29 to S42	Rotary: 12 position, 1 section	209256
S43	Toggle: S.P.S.T.	94128
S44	Lever: 3 position, 4 pole	209587
S45	Rotary: 24 position, 4 section	209250
S46	Lever: 2 position, 4 pole	209586
S47	Same as S12	
S48	Rotary: 11 position, 1 section	209255
S49	Rotary: 6 position, 3 section	209254
S50	Switch, Rotary, 12-position, 1 pole	217669
S51/R166	Switch and pot assembly, comprising SPST snap-on switch and 5 megohm potentiometer	217667
S52, S53	Switch, lever, 4-pole, 3-position	217670
T1	Transformer: filament	209590
T2	Transformer: current	209842
T3	Transformer: power	209589
T4	Transformer: power (oscillator)	209591
T5	Transformer, Filament	209590-A
T6	Transformer, Screen Grid, V-10	217671
TC1, TC2	Tube Plate Cap & Lead assembly with ferrite cores L-15, L-16	217672
TC3	Cap: tube, top cap, porcelain	207701
XV1	Socket: tube, octal	68590
XV2 XV3	Socket: tube, 7 pin miniature	94925
XV4	Same as XV1	68590
XV5	Same as XV2	94925
XV6 to XV9	Socket: tube, noval	94926
XI-1	Socket: neon indicator	56610
XI-2	Socket: pilot light	57752
XF1	Holder: fuse	48894

Symbol No.	Description	Stock No.
	Catch: top panel	209811
	Cover: cabinet dust cover	209858
	Cup: grooved knob	209810
	Dial, Cathode Decade Selector	217679
	Eyelet: cable	204509
	Foot: cabinet rubber foot	214961
	Grommet: power cable strain relief	79295
	Handle: cabinet carrying	30925
	Jewel: indicator light, clear plastic	208080
	Jewel: pilot light, red	57746
	Knob: control, Filament Range Selector	209855
	Knob: control, Range Selector, 3-10-30-100 volt	209851
	Knob: control, Cathode Resistor	209848
	Knob: control, Grid Resistor	209852
	Knob: control, Pin Switch	209850
	Knob: control, Current Limit Selector	209853
	Knob: control, Tube Drop Voltage Range	209854
	Knob: control, Transconductance Range Selector	209849
	Knob: control, Current Range Selector	209856
	Knob: control, gm/Current Selector	209857
	Knob: control, grooved	209594
	Knob: control, Current Zero Adjust	209593
	Knob: lever switch #8-32 tapped hole	209582
	Knob: push button	209585
	Knob & Dial, Filament Range Selector	217676
	Knob & Dial, Cathode Resistor	217677
	Knob & Dial, Grid Resistor	217678
	Latch: compartment door	95481
	Panel: control panel escutcheon	209847
	Plate: capacitor mtg., phenolic	28452
	Plate: capacitor mtg., phenolic	18469
	Plate: capacitor mtg., steel	19984
	Ring: knob shaft retaining	78651
	Spring, Plug-in Unit Retainer	209809
	Tube pin straightener: 7 pin	209583
	Tube pin straightener: 9 pin	209584
	Washer: fiber, $\frac{3}{8}$ " hole, $\frac{1}{2}$ " shoulder "Walsco 7864"	
	Washer: fiber, $\frac{3}{8}$ " hole, "Walsco 7844"	

Multiple Socket Plug-in Units

Symbol No.	Description	Stock No.
WG-229A		
	Connector: male, 16 contact chassis mtg.	209672
	Socket: tube, octal	215417
	Socket: tube, 9 pin, miniature	94926
	Socket: tube, 7 pin, miniature	94925
WG-230A		
	Connector: male, 16 contact, chassis mtg.	209672
	Socket: tube, 7 pin, combination	209577
	Socket: tube, 8 pin, lock-in type	209576

Symbol No.	Description	Stock No.
WG-231A		
	Connector: male, 16 contact, chassis mtg.	209672
	Socket: tube, 4 pin	17731
	Socket: tube, 5 pin	95269
	Socket: tube, 6 pin	209575
WG-232A		
	Connector: male, 16 contact, chassis mtg.	209672
	Socket: tube, 5 and 7 pin, acorn type	209578
	Socket: tube, 8 pin, sub-miniature	209580
	Socket: tube, 7 pin, flat type	209581

Warranty

Radio Corporation of America warrants its test and measuring equipment, when properly registered, against defects in workmanship, materials, and construction under normal use and service for a period of one year from the date of original purchase. Under this warranty, our obligation is limited to repairing or replacing any defective parts.

This warranty does not apply to any instrument which has been tampered with in any

way, or which has been misused or damaged by accident or negligence, or which has had the serial number removed, altered, or effaced.

RCA tubes and RCA batteries used in such equipment are covered by our standard tube or battery warranty.

This warranty is valid only when the card enclosed with the instrument is properly filled in and returned for registration.

Electron Tube Division
RADIO CORPORATION OF AMERICA
Harrison, New Jersey

